

Miniature circuit breaker ETIMAT 6

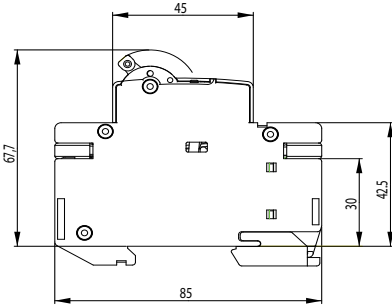

Technical data	
Rated voltage	230/400 V AC, max. 60 V DC
Rated current	B:1-63A, C:0.5-63A, D:0.5-63A
Rated frequency	50/60 Hz
Rated short-circuit capacity	6 kA
Back-up fuse	100A gG
Energy limiting class	3; B, C
Tripping characteristic	B, C, D
Terminals	1 – 25 mm <sup>2</sup> , max. 3 Nm
Terminal screw	M5 (Pozidrive PZ2)
Build-in width	18 mm/pol
Mounting on the rail	EN 60715 (EN 50022)
Busbar Thickness	0,8-2mm
Mounting position	any
Sealing possibility	ON / OFF
Electrical endurance (ops)	8.000
Mechanical endurance (ops)	20.000
Overtoltage category	III
Resistance to vibrations acc. to IEC 60068-2-7	5g (10,60 & 500Hz)
Standards	IEC 60898, EN 60898, IEC 60947-2

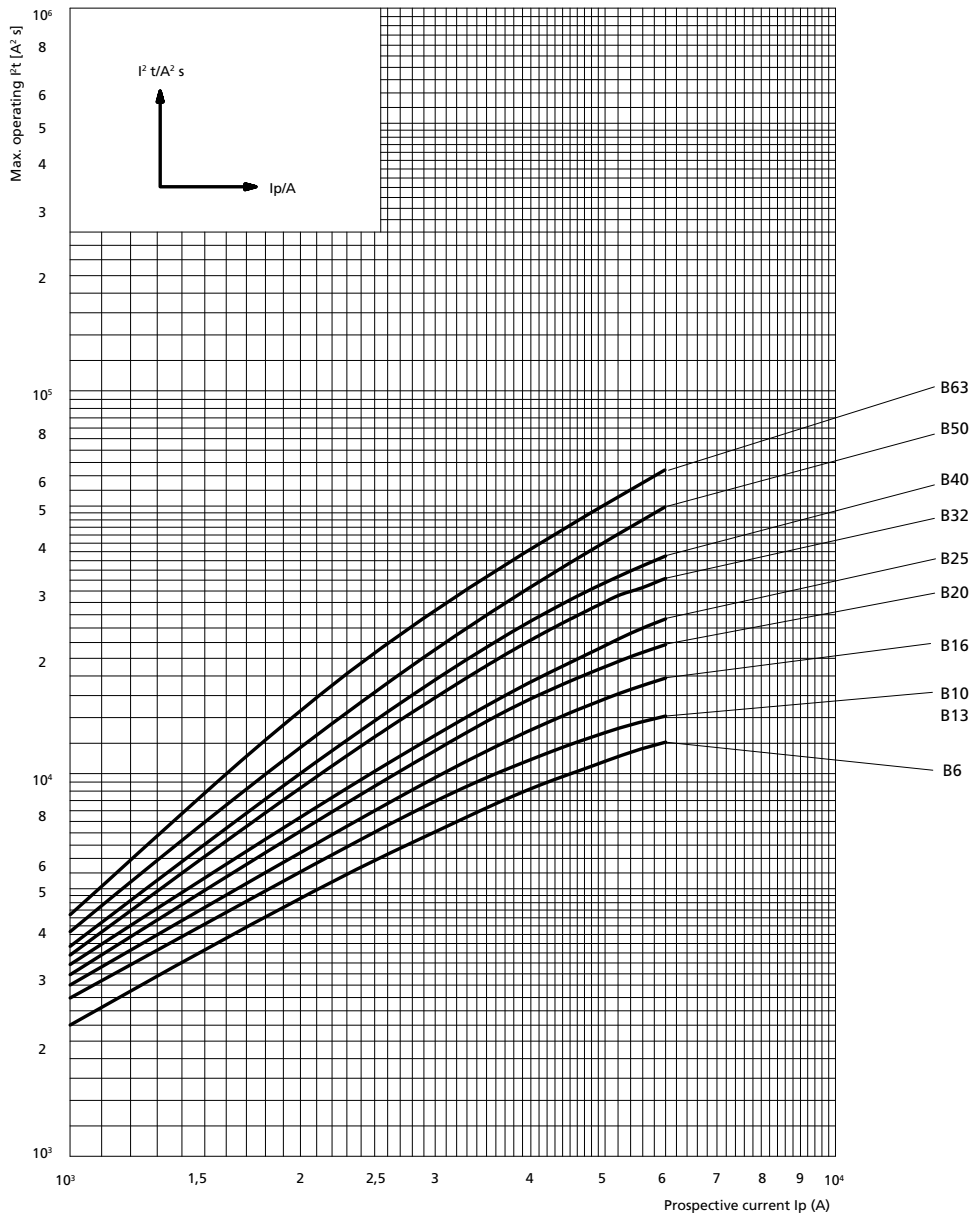

Technical data

Tripping characteristics

Characteristic	Test current	Tripping time	Result
B, C, D	$1,13 I_n$	$t \geq 3600 \text{ s}$	No tripping
B, C, D	$1,45 I_n$	$t < 3600 \text{ s}$	Tripping
B, C, D	$2,55 I_n$	$1 \text{ s} < t < 60 \text{ s}$	Tripping
B	$3,00 I_n$	$t \leq 0,1 \text{ s}$	No tripping
C	$5,00 I_n$	$t \leq 0,1 \text{ s}$	No tripping
D	$10,00 I_n$	$t \leq 0,1 \text{ s}$	No tripping
B	$5,00 I_n$	$t < 0,1 \text{ s}$	Tripping
C	$10,00 I_n$	$t < 0,1 \text{ s}$	Tripping
D	$20,00 I_n$	$t < 0,1 \text{ s}$	Tripping

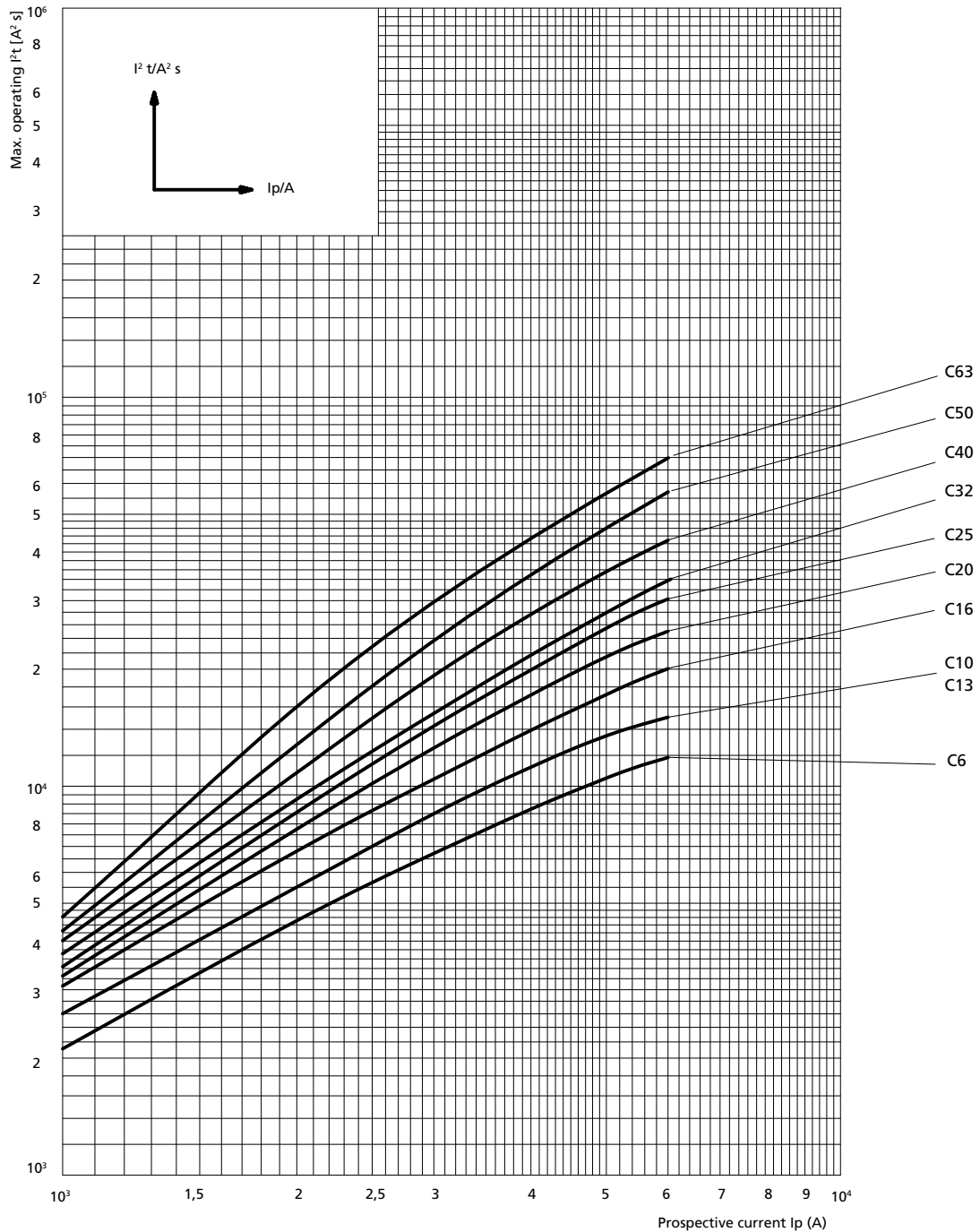
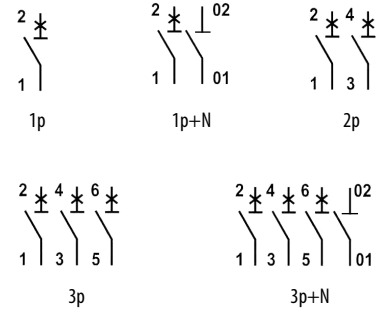

I/t characteristic at 50 and 60Hz

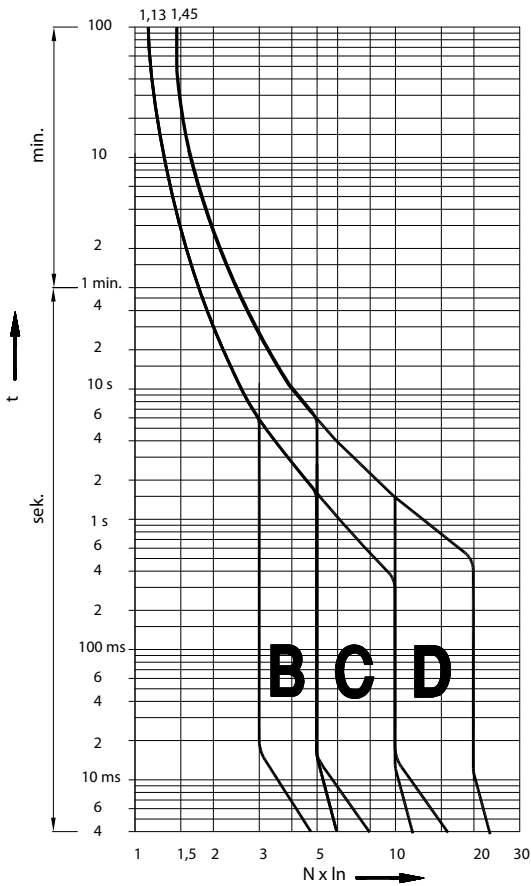

Conductor cross-section [mm²]	Number of single conductors, rigid, single-wire CU conductor				
	1	2	3	4	5
1,5	✓	✓	✓	✓	✗
2,5	✓	✓	✓	✗	✗
4	✓	✓	✓	✗	✗
6	✓	✓	✗	✗	✗
10	✓	✓	✗	✗	✗
16	✓	✗	✗	✗	✗
25	✓	✗	✗	✗	✗

Remark: When you use more than 2 cables you have to be careful how those cables are inserted, due to insure proper pressure on each cable

Conductor cross-section [mm²]	Number of single conductors, flexible Cu conductors without cable ferrule					
	1	2	3	4	5	6
1,5	✓	✓	✓	✓	✓	✓
2,5	✓	✓	✓	✓	✓	✓
4	✓	✓	✓	✓	✓	✓
6	✓	✓	✓	✗	✗	✗
10	✓	✓	✗	✗	✗	✗
16	✓	✗	✗	✗	✗	✗
25	✓	✗	✗	✗	✗	✗

Combination of rigid single-wire and flexible multi-wire Cu conductors is not allowed

Effect of the ambient temperature on the tripping characteristic



I <sub>n</sub> [A]	Ambient temperature T/°C												
	-40	-30	-20	-10	0	10	20	30	40	50	60	70	
0,5	0,61	0,6	0,59	0,57	0,56	0,54	0,52	0,5	0,47	0,44	0,41	0,38	
1	1,22	1,2	1,18	1,15	1,12	1,09	1,05	1	0,94	0,88	0,82	0,75	
1,6	1,95	1,92	1,89	1,84	1,79	1,74	1,68	1,6	1,51	1,42	1,32	1,2	
2	2,44	2,4	2,36	2,30	2,24	2,18	2,1	2	1,88	1,77	1,65	1,5	
4	4,88	4,8	4,72	4,61	4,49	4,36	4,20	4	3,77	3,55	3,29	3	
6	7,32	7,2	7,09	6,91	6,73	6,54	6,31	6	5,66	5,33	4,94	4,5	
10	12,2	12	11,8	11,5	11,2	10,9	10,5	10	9,44	8,89	8,23	7,5	
13	15,9	15,6	15,4	14,9	14,5	14,1	13,6	13	12,2	11,5	10,7	9,75	
16	19,5	19,2	18,9	18,4	17,9	17,4	16,8	16	15,1	14,2	13,2	12	
20	24,4	24	23,6	23	22,4	21,8	21	21	18,8	17,7	16,5	15	
25	30,5	30	2,5	28,8	28	27,2	26,3	25	23,6	22,2	20,6	18,8	
32	39	38,4	37,8	36,9	35,9	34,9	33,6	32	30,2	28,4	26,3	24	
40	48,8	48	47,8	46,1	44,9	43,6	42	40	37,7	35,5	32,9	30	
50	61	60	59,1	57,6	56,1	54,5	52,6	50	47,2	44,4	41,2	37,5	
63	76,9	75,6	74,4	72,6	70,7	68,7	66,2	63	59,4	56	51,9	47,3	

Correction factor is valid for current with times over 30 s  
 $I(x^{\circ}C)$  - test current at x ambient temperature  
 $I(30^{\circ}C)$  - test current at 30°C ambient temperature

$$k = \frac{I(x^{\circ}C)}{I(30^{\circ}C)}$$

Technical data

Resistance and power loss			
characteristic	$I_n$ [A]	R [mΩ]	P [w]
C, D	0,5	4500	1,12
	1	1800	1,80
	1,6	450	1,15
	2	280	1,08
	4	110	1,70
B, C, D	6	29	1,08
	10	13	1,30
	13	11,6	2,00
	16	9,0	2,30
	20	5,3	2,00
	25	4,1	2,50
	32	2,6	2,70
	40	1,96	3,20
	50	1,5	4,00
63	1,15	4,80	

Selectivity												
ETIMAT	gG NV											
	20	25	32	35	40	50	63	80	6,00	125	160	
B 6	0,5	0,78	1,2	1,4	1,7	2,4	4,6	6,0	6,0	6,0	6,0	
B 10/13	0,45	0,65	1,1	1,3	1,6	2,2	4,0	6,0	6,0	6,0	6,0	
B 16		0,55	1,0	1,2	1,5	2,0	3,6	5,5	6,0	6,0	6,0	
B 20			0,85	1,2	1,5	1,8	3,1	4,6	6,0	6,0	6,0	
B 25				1,1	1,4	1,7	2,9	4,0	6,0	6,0	6,0	
B 32					1,3	1,6	2,5	3,4	5,5	6,0	6,0	
B 40						1,5	2,2	3,1	4,9	6,0	6,0	
B 50							2,1	2,9	4,0	6,0	6,0	
B 63								2,5	3,3	5,1	6,0	

ETIMAT	gG NV											
	20	25	32	35	40	50	63	80	6,00	125	160	
C,D 6	0,52	0,82	1,3	1,5	2,0	2,7	5,1	6,0	6,0	6,0	6,0	
C,D 10/13	0,47	0,70	1,1	1,4	1,8	2,3	4,0	6,0	6,0	6,0	6,0	
C,D 16		0,61	0,92	1,2	1,5	1,9	3,2	5,0	6,0	6,0	6,0	
C,D 20			0,90	1,1	1,4	1,7	2,9	4,2	6,0	6,0	6,0	
C,D 25				1,0	1,3	1,6	2,7	3,9	6,0	6,0	6,0	
C,D 32					1,2	1,5	2,3	3,4	5,2	6,0	6,0	
C,D 40						1,4	2,1	3,0	4,6	6,0	6,0	
C,D 50							2,0	2,7	3,8	6,0	6,0	
C,D 63								2,3	3,2	5,5	6,0	

Miniature circuit breaker ETIMAT 1N

Technical data	
Rated voltage $U_n$	230 V AC
Rated current $I_n$	6-32 A
Rated frequency $f_n$	50/60Hz
Rated short-circuit capacity	6.000 A
Back-up fuse	100 A gG
Tripping characteristics	B, C
Overtoltage category	III
Energy limiting class	3
Terminals	1-10mm <sup>2</sup> , max. 1,5Nm
Build-in width	M4 (Pozidrive PZ2)
Mounting position	180°
Supply possibility	top or bottom
Standard	5g (10,60 & 500Hz) IEC 60898, EN 60898

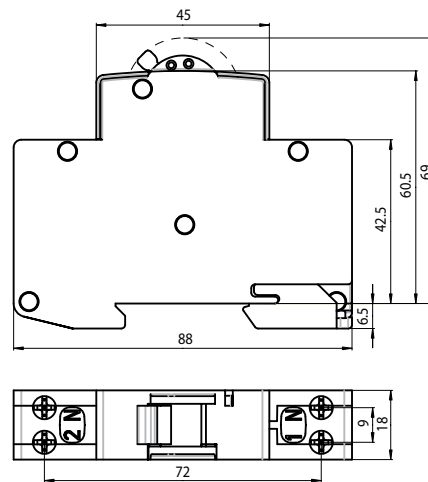

Auxiliary switch PS ETIMAT

Technical data	
Rated current	6A (230V AC), 1A (110V DC), 0,5A (220V DC)
Terminal	1-4mm <sup>2</sup>
Contact	1 xb-contact (NC) 1 xa-contact (NO)
Conditional short-circuit current	1 kA with fuse-link 20 A
Mounting position	any
Standard	EN-62019

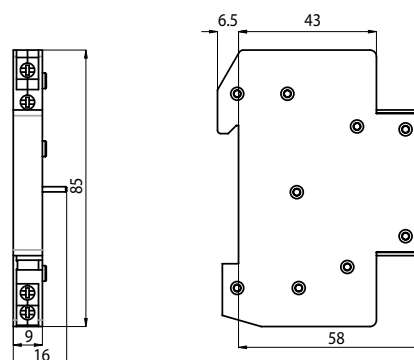

PS ETIMAT is an auxiliary switch only for ETIMAT 6.

## Shunt trip release DA ETIMAT

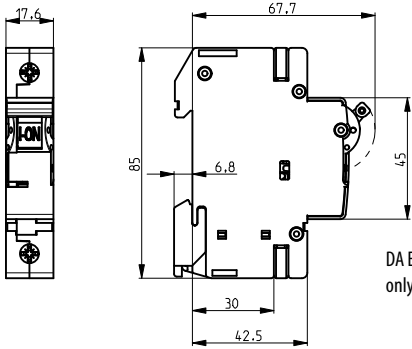

DA ETIMAT is a shunt trip release only for ETIMAT 6.

Technical data	
Nominal voltage	24V AC/DC, 48V AC/DC, 230V AC/DC
Rated frequency	50/60Hz
Max. inrush current	3,6 A
Build-in width	18mm
Mounting position	any
Mounting on the rail	EN 60715 (EN 50022)

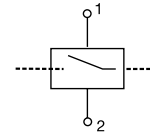

## Miniature circuit breaker ETIMAT P10

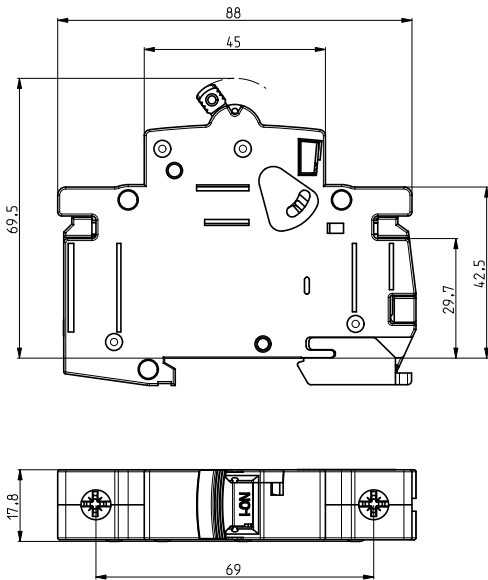

Technical data	
Rated voltage	230/400 V AC; max. 60 V DC
Rated current	B:1-63A, C:0.5-63A, D:0.5-32A, K, Z:0.5-32A
Rated frequency	50/60Hz
Shock resistance	30g.min. 2 shocks, t = 13ms
Rated short-circuit capacity	10 kA
Energy limiting class	3; B,C
Tripping characteristic	B, C, D, K, Z
Back-up fuse	100A gG
Index of protection	IP 20 (IP 40)
Terminals	1-25mm <sup>2</sup> , max. 2,5Nm
Terminal screw	M5 (Pozidrive PZ2)
Mechanical endurance	20000 op.c.
Electrical endurance	20000 op.c. (I <sub>n</sub> ≤ 32A), 10000 op.c. (I <sub>n</sub> > 32A)
Ambient temperature	max. -25°C ... +55°C
Storage temperature	max. -40°C ... +70°C
Supply possibility	top or bottom
Build-in width	18 mm/pol
Insulating class	B
Overtoltage category	III
Mounting on the rail	EN 60715
Mounting position	any
Sealing possibility	✓
Terminal cover	✓
Locking device	✓
Resistance to vibrations acc. to IEC 60068-2-7	5g (10,60 & 500Hz)
Standards	EN 60898, IEC 60898, EN 60947-2

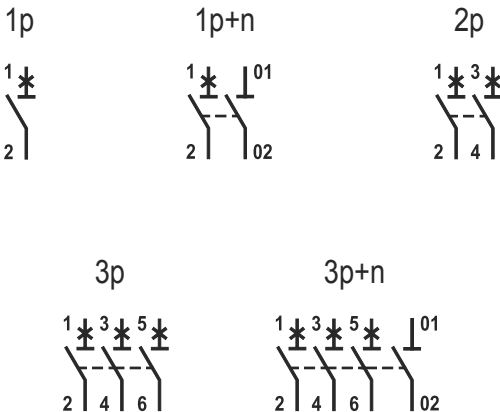

Tripping characteristics			
Characteristic	Test current	Tripping time	Result
B, C, D	1,13 I <sub>n</sub>	t ≥ 3600 s	No tripping
B, C, D	1,45 I <sub>n</sub>	t < 3600 s	Tripping
B, C, D	2,55 I <sub>n</sub>	1s < t < 60 s	Tripping
B	3,00 I <sub>n</sub>	t ≤ 0,1 s	No tripping
C	5,00 I <sub>n</sub>	t ≤ 0,1 s	No tripping
D	10,00 I <sub>n</sub>	t ≤ 0,1 s	No tripping
B	5,00 I <sub>n</sub>	t < 0,1 s	Tripping
C	10,00 I <sub>n</sub>	t < 0,1 s	Tripping
D	20,00 I <sub>n</sub>	t < 0,1 s	Tripping
K	1,05 I <sub>n</sub>	t > 7200 s	No Tripping
K	1,20 I <sub>n</sub>	t < 7200 s	Tripping
K	8,00 I <sub>n</sub>	t ≤ 0,2 s	No Tripping
K	12,00 I <sub>n</sub>	t < 0,2 s	Tripping
Z	2,00 I <sub>n</sub>	t ≤ 0,2s	No Tripping
Z	3,00 I <sub>n</sub>	t < 0,2s	Tripping

Technical data

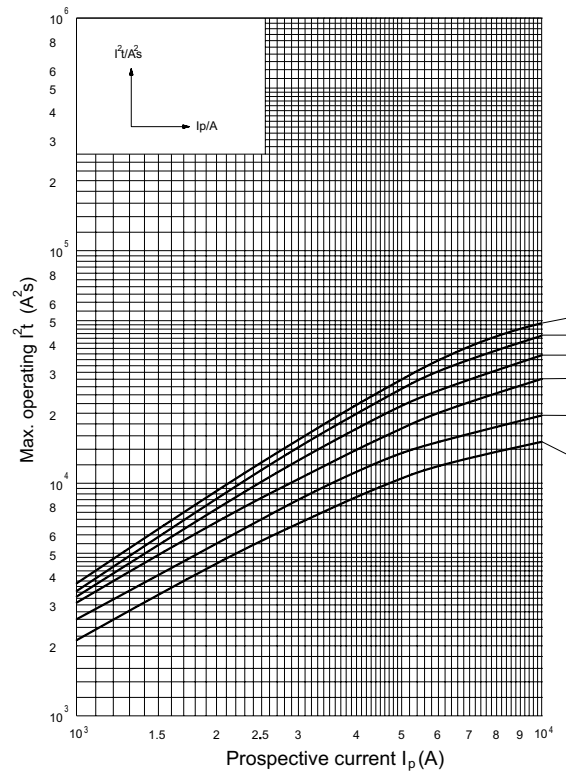
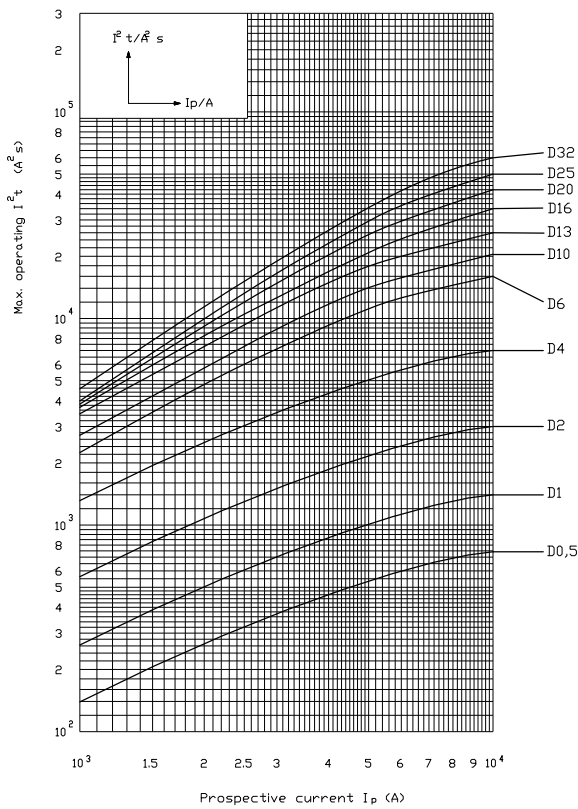
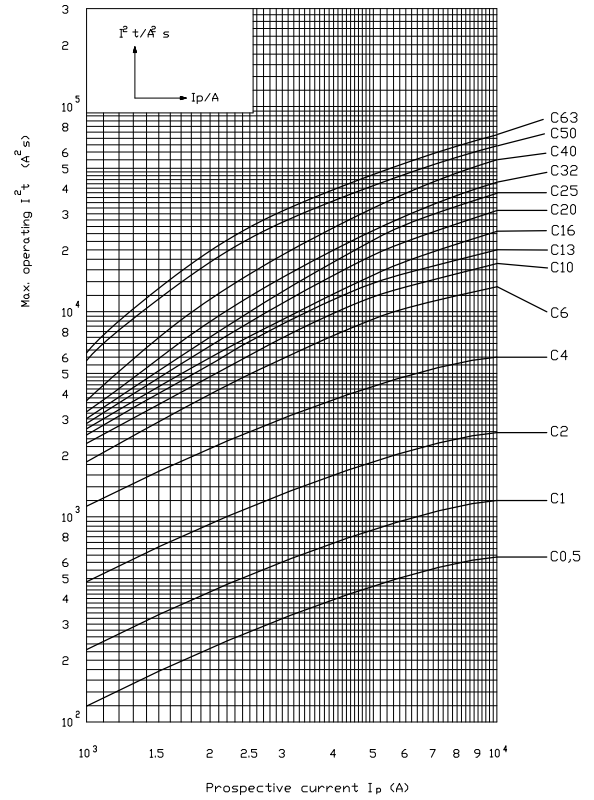
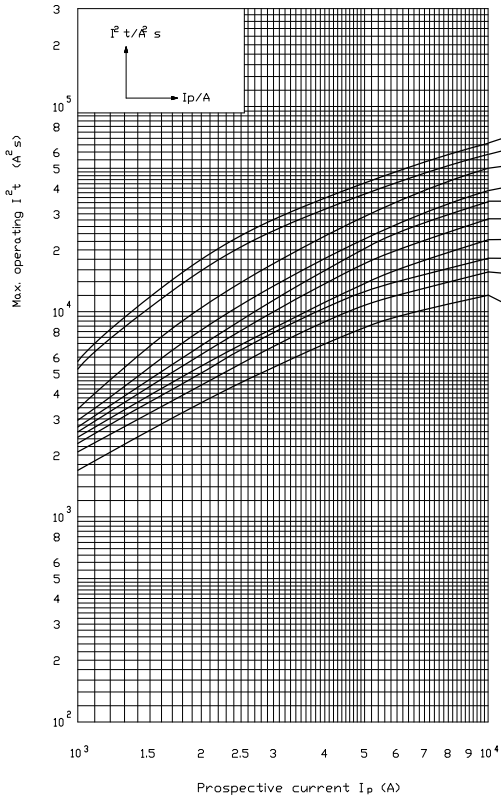

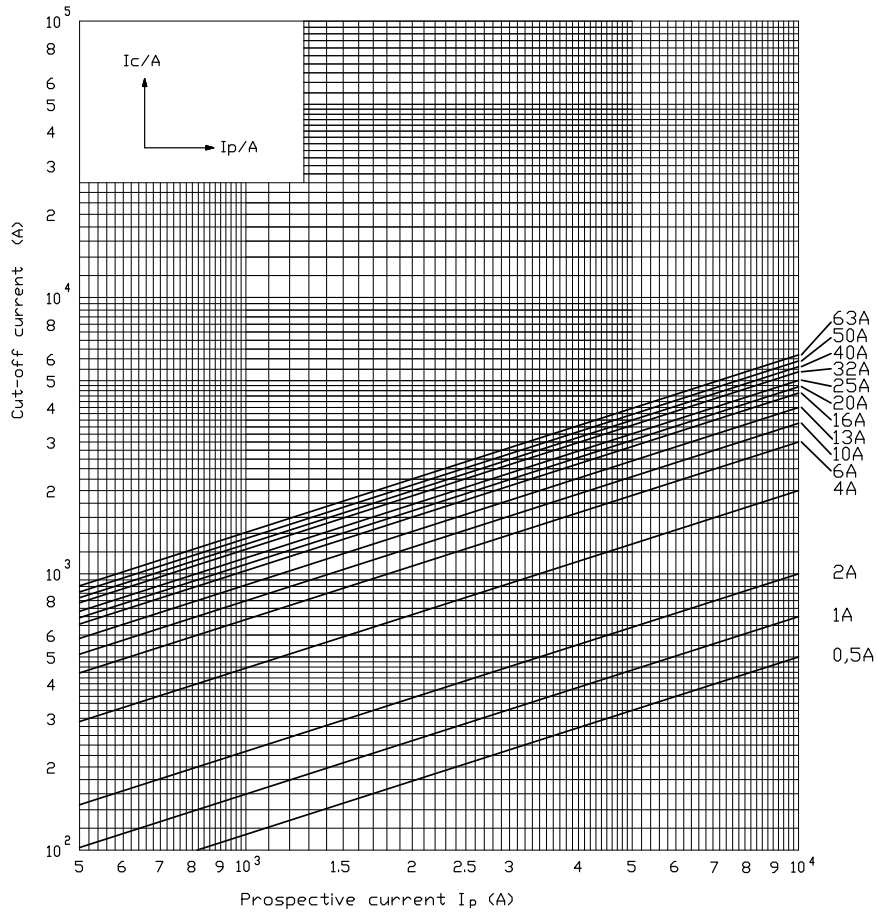

I/t characteristic at 50 and 60Hz

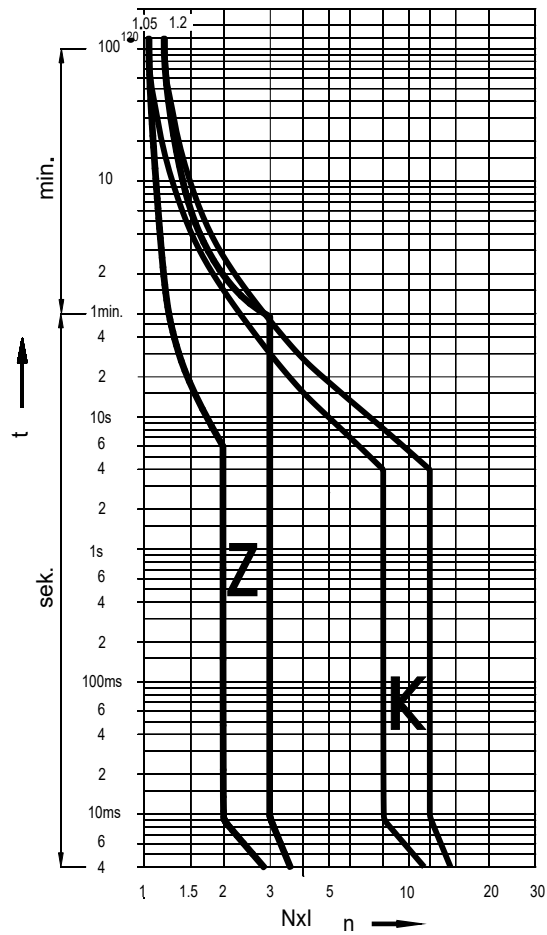
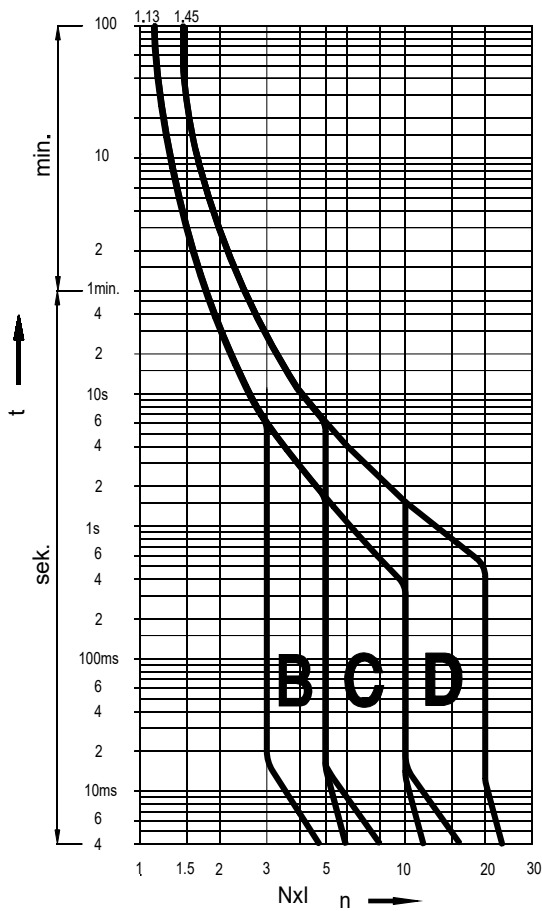

Technical data

Effect of the ambient temperature on the tripping characteristic

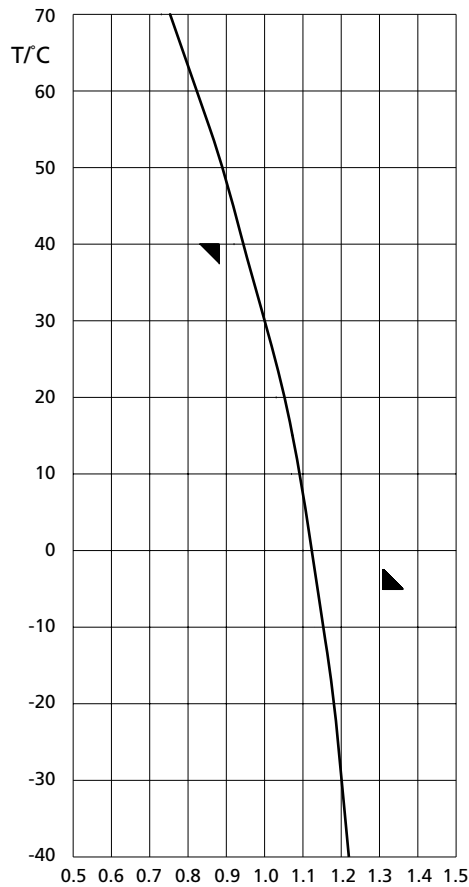

Correction factor is valid for current with times over 30 s  
 $I(x^{\circ}C)$  - test current at x ambient temperature  
 $I(30^{\circ}C)$  - test current at 30°C ambient temperature

$$k = \frac{I(x^{\circ}C)}{I(30^{\circ}C)}$$

$I_n$ [A]	Ambient temperature T/°C											
	-40	-30	-20	-10	0	10	20	30	40	50	60	70
0,5	0,61	0,6	0,59	0,57	0,56	0,54	0,52	0,5	0,47	0,44	0,41	0,38
1	1,22	1,2	1,18	1,15	1,12	1,09	1,05	1	0,94	0,88	0,82	0,75
1,6	1,95	1,92	1,89	1,84	1,79	1,74	1,68	1,6	1,51	1,42	1,32	1,2
2	2,44	2,4	2,36	2,30	2,24	2,18	2,1	2	1,88	1,77	1,65	1,5
4	4,88	4,8	4,72	4,61	4,49	4,36	4,20	4	3,77	3,55	3,29	3
6	7,32	7,2	7,09	6,91	6,73	6,54	6,31	6	5,66	5,33	4,94	4,5
10	12,2	12	11,8	11,5	11,2	10,9	10,5	10	9,44	8,89	8,23	7,5
13	15,9	15,6	15,4	14,9	14,5	14,1	13,6	13	12,2	11,5	10,7	9,75
16	19,5	19,2	18,9	18,4	17,9	17,4	16,8	16	15,1	14,2	13,2	12
20	24,4	24	23,6	23	22,4	21,8	21	21	18,8	17,7	16,5	15
25	30,5	30	2,5	28,8	28	27,2	26,3	25	23,6	22,2	20,6	18,8
32	39	38,4	37,8	36,9	35,9	34,9	33,6	32	30,2	28,4	26,3	24
40	48,8	48	47,8	46,1	44,9	43,6	42	40	37,7	35,5	32,9	30
50	61	60	59,1	57,6	56,1	54,5	52,6	50	47,2	44,4	41,2	37,5
63	76,9	75,6	74,4	72,6	70,7	68,7	66,2	63	59,4	56	51,9	47,3

Conductor cross-section [mm <sup>2</sup> ]	Number of single conductors, rigid, single-wire CU conductor				
	1	2	3	4	5
1,5	✓	✓	✓	✓	✗
2,5	✓	✓	✓	✗	✗
4	✓	✓	✓	✗	✗
6	✓	✓	✗	✗	✗
10	✓	✓	✗	✗	✗
16	✓	✗	✗	✗	✗
25	✓	✗	✗	✗	✗

Remark: When you use more than 2 cables you have to be careful how those cables are inserted, due to insure proper pressure on each cable

Conductor cross-section [mm <sup>2</sup> ]	Number of single conductors, flexible Cu conductors without cable ferrule					
	1	2	3	4	5	6
1,5	✓	✓	✓	✓	✓	✓
2,5	✓	✓	✓	✓	✓	✓
4	✓	✓	✓	✓	✓	✓
6	✓	✓	✓	✗	✗	✗
10	✓	✓	✗	✗	✗	✗
16	✓	✗	✗	✗	✗	✗
25	✓	✗	✗	✗	✗	✗

Combination of rigid single-wire and flexible multi-wire Cu conductors is not allowed



Resistance and power loss

characteristic	I <sub>n</sub> [A]	R [mΩ]	P [w]
C, D, K, Z	0,5	5700	1,43
	1	1540	1,54
	2	365	1,46
	4	104	1,66
B, C, D, K, Z	6	47	1,68
	10	21	2,1
	13	13,1	2,21
	16	9,7	2,48
	20	6,8	2,70
	25	5,0	3,13
B, C	32	3,1	3,2
	40	2,4	3,80
	50	1,7	4,25
	63	1,23	4,90

Selectivity

type	gG NV [kA]										
	20	25	32	35	40	50	63	80	100	125	160
B 6	0,5	0,78	1,2	1,4	1,7	2,4	4,6	7,0	10	10	10
B 10/13	0,45	0,65	1,1	1,3	1,6	2,2	4,0	6,5	10	10	10
B 16		0,55	1,0	1,2	1,5	2,0	3,6	5,5	9,5	10	10
B 20			0,85	1,2	1,5	1,8	3,1	4,6	9,0	10	10
B 25				1,1	1,4	1,7	2,9	4,0	8,0	10	10
B 32					1,3	1,6	2,5	3,4	5,5	9,0	10
B 40						1,5	2,2	3,1	4,9	8,0	10
B 50							2,1	2,9	4,0	6,2	10
B 63								2,5	3,3	5,1	8,0

type	gG NV [kA]										
	20	25	32	35	40	50	63	80	100	125	160
C,D,K,Z 6	0,52	0,82	1,3	1,5	2,0	2,7	5,1	9,0	10	10	10
C,D,K,Z 10/13	0,47	0,70	1,1	1,4	1,8	2,3	4,0	7,0	10	10	10
C,D,K,Z 16		0,61	0,92	1,2	1,5	1,9	3,2	5,0	9,0	10	10
C,D,K,Z 20			0,90	1,1	1,4	1,7	2,9	4,2	8,0	10	10
C,D,K,Z 25				1,0	1,3	1,6	2,7	3,9	6,0	10	10
C,D,K,Z 32					1,2	1,5	2,3	3,4	5,2	9,0	10
C 40						1,4	2,1	3,0	4,6	8,0	10
C 50							2,0	2,7	3,8	7,0	10
C 63								2,3	3,2	5,5	9,0

Miniature circuit breaker ETIMAT P10 QC (screwless terminal)

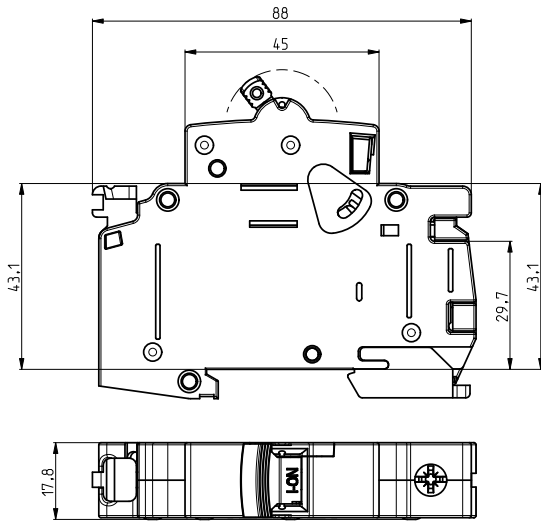

Technical data

Rated voltage	230/400 V AC; max. 60 V DC
Rated current	B:6-20A, C:0.5-20A, D:0.5-20A, K:0.5-20A
Rated frequency	50/60Hz
Shock resistance	30g.min. 2 shocks, t = 13ms
Rated short-circuit capacity	10 kA
Energy limiting class	3; B,C
Tripping characteristic	B, C, D, K
Back-up fuse	100A gG
Index of protection	IP 20 (IP 40)
Terminals	1-4mm <sup>2</sup>
Mechanical endurance	20000 op.c.
Electrical endurance	20000 op.c.
Ambient temperature	max. -25°C to +55°C
Storage temperature	max. -40°C to +70°C
Build-in width	18 mm/pol
Insulating class	B
Mounting on the rail	EN 60715
Mounting position	any
Sealing possibility	✓
Terminal cover	✓
Locking device	✓
Resistance to vibrations acc. to IEC 60068-2-7	5g (10,60 & 500Hz)
Standards	EN 60898, IEC 60898, EN 60947-2

1p



1p+n

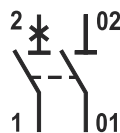

2p



3p

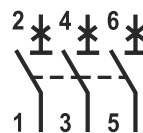

3p+n

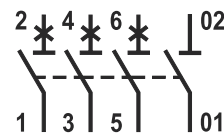

Technical data

Miniature circuit breaker ETIMAT RC (Remote Control)

Technical data	
Rated voltage	230V
Rated current	B: 6-63 A, C: 6-63 A
Rated frequency	50/60Hz
Energy limiting class	3
Back-up fuse	100 A gG
Index of protection	IP 20 (IP 40)
Terminals	max. 1.5mm <sup>2</sup> , max. 0.8Nm
Mechanical endurance	20000 op.c.
Ambient temperature	max. 35°C
Storage temperature	max. -40°C... +70°C
Mounting on the rail	EN 60715
Mounting position	any
Sealing possibility	✓
Terminal cover	✓
Locking device	✓
No. of poles	1, 2, 3, 4

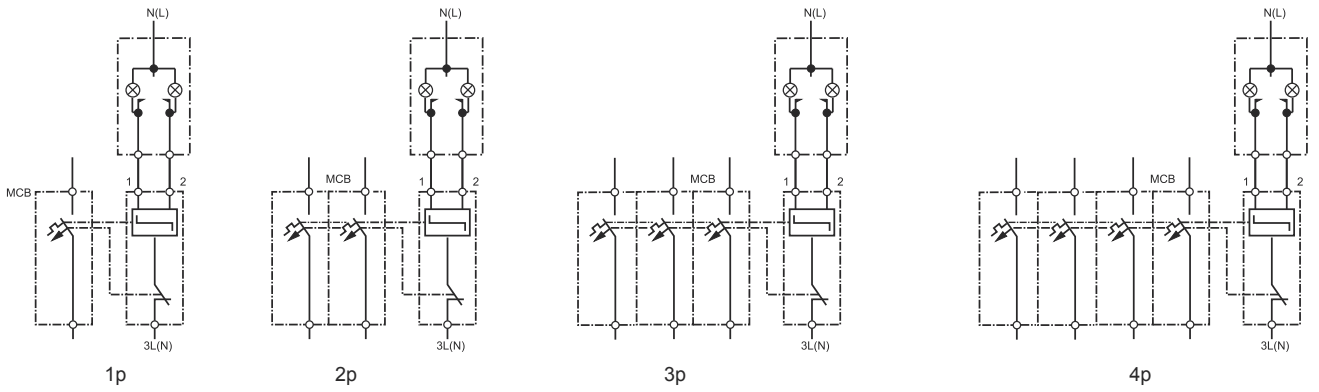
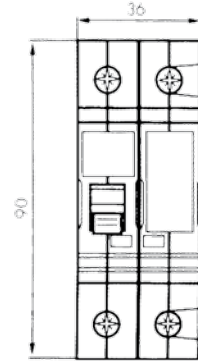

Conductor cross-section [mm <sup>2</sup> ]	Number of single conductors, rigid, single-wire Cu conductor				
	1	2	3	4	5
1,5	✓	✓	✓	✓	✗
2,5	✓	✓	✓	✗	✗
4	✓	✓	✓	✗	✗
6	✓	✓	✗	✗	✗
10	✓	✓	✗	✗	✗
16	✓	✗	✗	✗	✗
25	✓	✗	✗	✗	✗

Remark: When you use more than 2 cables you have to be careful how those cables are inserted, due to insure proper pressure on each cable

Conductor cross-section [mm <sup>2</sup> ]	Number of single conductors, flexible Cu conductors without cable ferrule					
	1	2	3	4	5	6
1,5	✓	✓	✓	✓	✓	✓
2,5	✓	✓	✓	✓	✓	✓
4	✓	✓	✓	✓	✓	✓
6	✓	✓	✓	✗	✗	✗
10	✓	✓	✗	✗	✗	✗
16	✓	✗	✗	✗	✗	✗
25	✓	✗	✗	✗	✗	✗

Combination of rigid single-wire and flexible multi-wire Cu conductors is not allowed

# Miniature circuit breaker ETIMAT P10 DC

Technical data	
Rated voltage - for 1-pole $U_n$	220 V DC
- for 2-pole $U_n$	220 V / 440 V DC
Rated time constant L/R	4 ms
Rated current $I_n$	0,5-32A (K & Z), 0,5-63A (B & C)
Rated short-circuit capacity	10 kA
Tripping characteristic	B, C, K, Z
Energy limiting class	3
Insulating class	B
Back-up fuse	100 A gG
Terminals	1-25mm <sup>2</sup> , max. 2,5Nm
Terminal screw	M5 (Pozidrive PZ2)
Mounting position	any
Resistance to vibrations (IEC 60068-2-7)	5g (10,60 & 500Hz)
Standards	IEC 60898, EN 60898, DIN VDE 0641

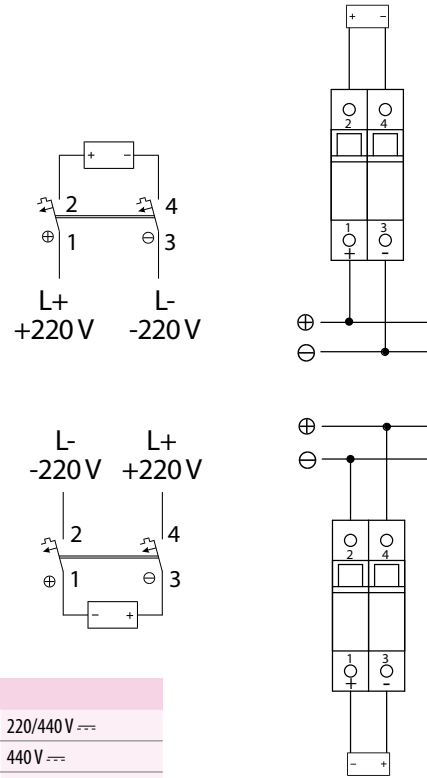
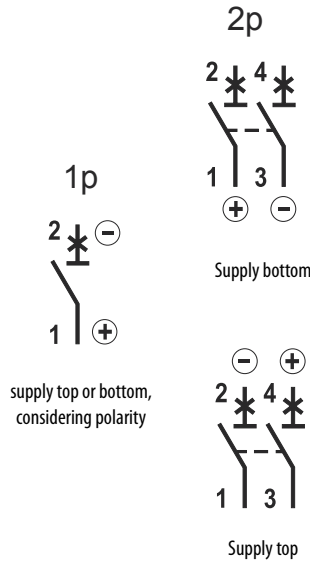

## Connecting diagrams in direct current electric circuits

Rated voltage of circuit breaker	220 V ---	220/440 V ---	220/440 V ---	220/440 V ---
Voltage between conductors - max.	220 V ---	440 V ---	440 V ---	440 V ---
Voltage between conductor and earth - max.	220 V ---	220 V ---	440 V ---	220 V ---
Circuit breaker	1-pole	2-pole	2-pole	2-pole
Connecting diagram				

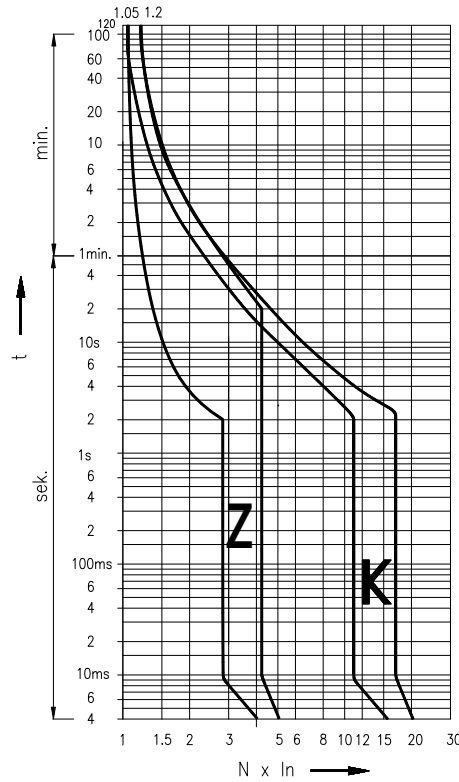
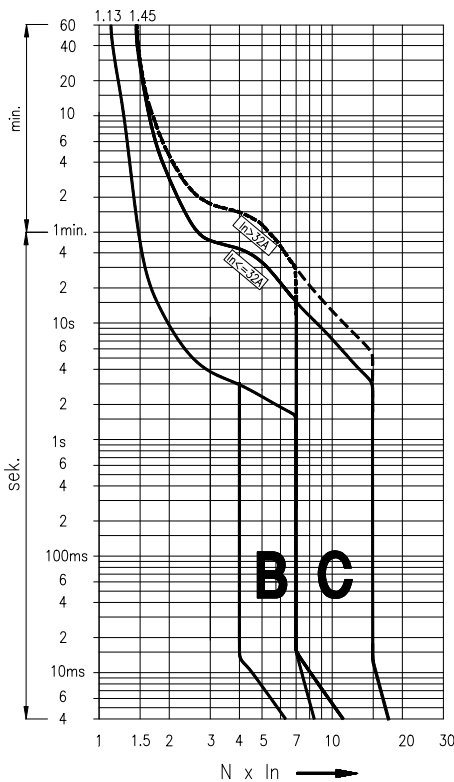

Conductor cross-section [mm <sup>2</sup> ]	Number of single conductors, rigid, single-wire CU conductor				
	1	2	3	4	5
1,5	✓	✓	✓	✓	✗
2,5	✓	✓	✓	✗	✗
4	✓	✓	✓	✗	✗
6	✓	✓	✗	✗	✗
10	✓	✓	✗	✗	✗
16	✓	✗	✗	✗	✗
25	✓	✗	✗	✗	✗

Remark: When you use more than 2 cables you have to be careful how those cables are inserted, due to insure proper pressure on each cable

Conductor cross-section [mm <sup>2</sup> ]	Number of single conductors, flexible Cu conductors without cable ferrule					
	1	2	3	4	5	6
1,5	✓	✓	✓	✓	✓	✓
2,5	✓	✓	✓	✓	✓	✓
4	✓	✓	✓	✓	✓	✓
6	✓	✓	✓	✗	✗	✗
10	✓	✓	✗	✗	✗	✗
16	✓	✗	✗	✗	✗	✗
25	✓	✗	✗	✗	✗	✗

Combination of rigid single-wire and flexible multi-wire Cu conductors is not allowed

Technical data

### Auxiliary signal switch PS/SS E P10

Technical data	
Rated voltage	230V AC/DC, 110V DC
Rated current	6A (230V AC); 1A (110V DC); 0,5A (220V DC)
Rated frequency	50/60Hz, DC
Index of protection	IP 20 (IP 40)
Terminals	max. 1.5mm <sup>2</sup> , max 0.8Nm
Ambient temperature	max. 35°C
Storage temperature	max. -40°C to +70°C
Contacts	1x NC, 1x NC/NO
Mounting position	any
Standards	EN 62019

AUX switch connections	status of the breaker	
	ON	OFF
11-14 NO	1	0
11-12 NC	0	1
21-22 NC	0	1

Signal switch connections	status of the breaker		
	ON	manual trip	overcurrent trip
11-14 NO	1	1	0
11-12 NC	0	0	1
21-22 NC	0	0	1

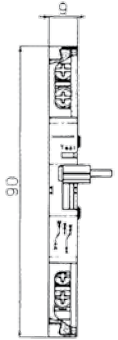

NO - Normally open contact --> during the activation it makes a contact  
 NC - Normally closed contact --> during the activation it brakes the contact  
 1 - contact  
 0 - without a contact

### Shunt trip release DA ETIMAT P10

Technical data	
Rated voltage	12-60V AC/DC, 110-250V AC/DC
Rated frequency	50/60Hz, DC
Max inrush current	3A
Index of protection	IP 20 (IP 40)
Terminals	1-25mm <sup>2</sup> , max. 2,5Nm
Ambient temperature	M5 (Pozidrive PZ2)
Terminal screw	max. 35°C
Storage temperature	max. -40°C to +70°C
Mounting on the rail	EN 60715
Mounting position	any
Sealing possibility	✓
Terminal cover	✓
Locking device	✓

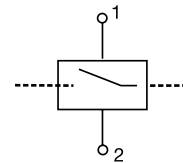

Note: Same dimensions as ETIMAT P10

### Undervoltage release UA ETIMAT P10

Technical data		
Type	UA ETIMAT P10/48V	UA ETIMAT P10/230V
Rated voltage	48V	230V
Rated frequency	50/60Hz	
Tripping area	<35% U <sub>n</sub> tripping 35%-70% U <sub>n</sub> tripping or no tripping >70%U <sub>n</sub> no tripping	
Consumption	3,8 VA	
Build-in width	18 mm	
Mounting position	any	
Standards	IEC/EN 60947-1	

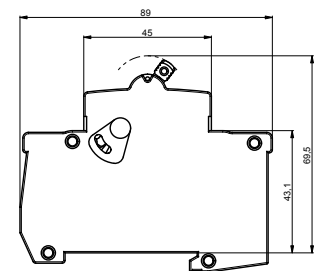

1p

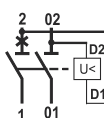

3p

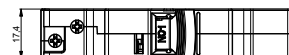
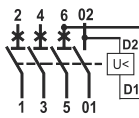

### Miniature circuit breaker ETIMAT 10 80-125 A

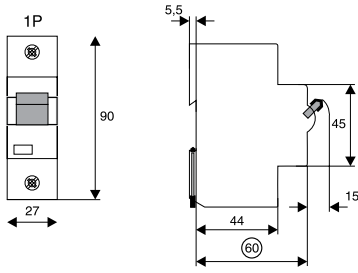

ETIMAT 10, 80-125 A,

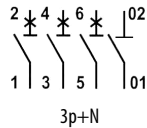
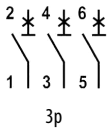
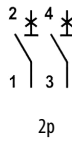
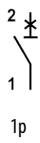

**Technical data**

Rated voltage	80-125 A	230/400V AC, 60V DC
Rated current	80, 100, 125 A	
Tripping characteristics	B, C, D	
Rated frequency	50/60 Hz	
Rated insulation voltage	440V AC (80-125A)	
Rated impulse withstand voltage $U_{imp}$	4kV (80-125A)	
Rated short-circuit capacity:	Characteristic B, C	$I_n=80, 100 A$ 20kA (EN 60947-2)
		$I_n=125 A$ 15kA (EN 60947-2)
	Characteristic D	$I_n=80 A$ 20kA (EN 60947-2)
		$I_n=100 A$ 15kA (EN 60947-2)
Energy limiting class	3	
Terminals	80-125 A	2,5-50mm <sup>2</sup>
Build-in width	80-125 A	27mm/Pol
Mounting on the rail	EN 60715 (EN 50022)	
Mounting position	any	
Mechanical durability (cycles)	80-125 A	min. 20000
Sealing possibility	ON / OFF	
Resistance to vibrations (IEC 60068-2-7)	5g (10,60 & 500Hz)	
Standards	EN 60898, EN 60947-2	

### Auxiliary switch PSM 80 - 125 A

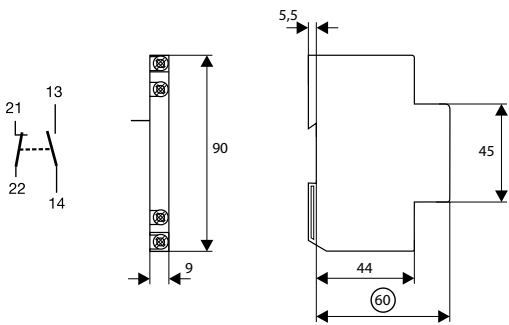

**Technical data**

Rated current	6 A / AC13 (250 V AC)
Rated thermal current $I_{th}$	8 A
Rated insulation voltage	440 V AC
Max. back-up fuse	6A
Contacts	1x a-contact, 1x b-contact
Utilization category AC-13	6 A/250 V AC
	2 A/440 V AC
Utilization category DC-13	4 A/600 V DC
	2 A/110 V DC
	0,5 A/230 V DC
Build-in width	9 mm/Pol
Mounting position	any
Mounting on the rail	EN 60715 (EN 50022)
Terminals	1x1mm <sup>2</sup> ... 2x2,5mm <sup>2</sup>
Standard	EN 60947-5-1

### Shunt trip release DA ETIMAT 10 80 - 125A

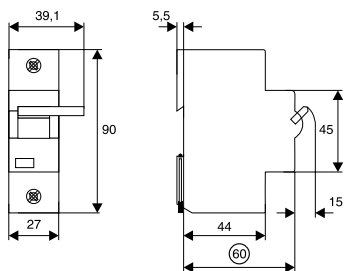

**Technical data**

Rated voltage	110-415V AC
Rated frequency	50/60Hz
Index of protection	IP 20 (IP 40)
Storage temperature	max. -40°C ... +70°C
Mounting on the rail	EN 60715
Mounting position	any
Standards	EN 60715

Technical data

Current overload limiter OSP-P10

Technical data	
Rated voltage $U_n$	230/400 V
Rated current $I_n$	6, 10, 16, 20, 25, 32, 40, 50, 63 A
Rated short-circuit capacity	10.000 A
Back-up fuse	100 A gG
Rated frequency $f_n$	50/60 Hz
Terminal	1 - 25mm <sup>2</sup>
Mounting position	any
Standards	IEC 60898, EN 60898

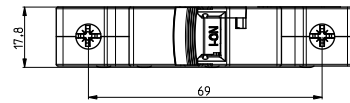
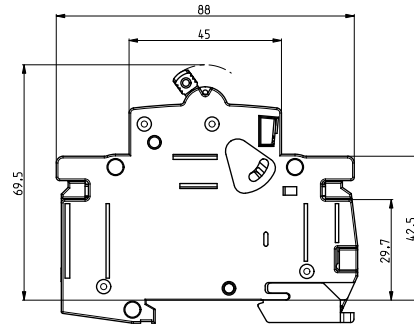

Tripping characteristics		
Test current	Tripping time	Result
$1,05 \times I_n$	$t > 3600$ s	No tripping
$1,2 \times I_n$	$2 < t < 900$ s	Tripping
$2,5 \times I_n$	$0,5 < t < 60$ s	Tripping
$8 \times I_n$	$t \leq 0,1$ s	No tripping
$12 \times I_n$	$t < 0,1$ s	Tripping

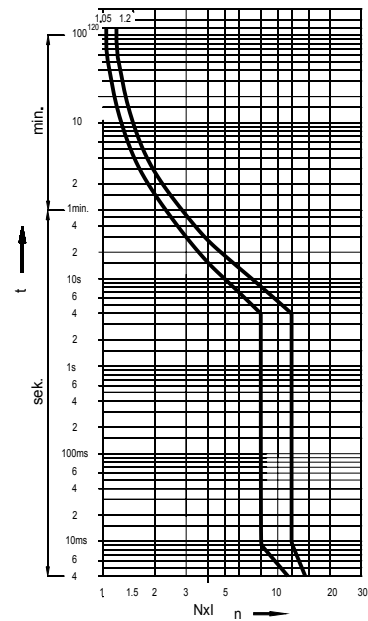

Conductor cross-section [mm <sup>2</sup> ]	Number of single conductors, rigid, single-wire CU conductor				
	1	2	3	4	5
1,5	✓	✓	✓	✓	✗
2,5	✓	✓	✓	✗	✗
4	✓	✓	✓	✗	✗
6	✓	✓	✗	✗	✗
10	✓	✓	✗	✗	✗
16	✓	✗	✗	✗	✗
25	✓	✗	✗	✗	✗

Remark: When you use more than 2 cables you have to be careful how those cables are inserted, due to insure proper pressure on each cable

Conductor cross-section [mm <sup>2</sup> ]	Number of single conductors, flexible Cu conductors without cable ferrule					
	1	2	3	4	5	6
1,5	✓	✓	✓	✓	✓	✓
2,5	✓	✓	✓	✓	✓	✓
4	✓	✓	✓	✓	✓	✓
6	✓	✓	✓	✗	✗	✗
10	✓	✓	✗	✗	✗	✗
16	✓	✗	✗	✗	✗	✗
25	✓	✗	✗	✗	✗	✗

Combination of rigid single-wire and flexible multi-wire Cu conductors is not allowed

## Residual current circuit breaker EFI-2

Technical data			
Type	Instantenous	G/KV type	S type
<b>Electrical</b>			
Rated voltage $U_n$	230/240V AC	230/240V AC	230/240V AC
Rated current $I_n$	16, 25, 40, 63, 80, 100A	25, 40, 63A	25, 40, 63A
Rated Insulation voltage $U_i$	440V	440V	440V
Rated frequency $f_n$	50/60Hz	50/60Hz	50/60Hz
Peak withstand current	-	3kA (8/20ms) surge current proof	5kA (8/20ms) surge current proof
Electrical isolation	> 4mm contact space	> 4mm contact space	> 4mm contact space
Rated residual operating current $I_{\Delta n}$	0,03; 0,1 & 0,3A	0,03; 0,1 & 0,3A	0,1 & 0,3A
Rated conditional short-circuit current $I_{cn}$	10kA	10kA	10kA
Rated making and breaking capacity $I_m$	800A	630A	630A
Maximum back-up fuse	100A gG	80A gG	80A gG
Isolation class	B	B	B
Standard	IEC/EN 61008	IEC/EN 61008, OVE E 8601	IEC/EN 61008
Mechanical endurance (op. c.)	> 4000	> 4000	> 4000
Electrical endurance (op. c.)	> 2000	> 2000	> 2000
<b>Mechanical</b>			
Frame size	45mm	45mm	45mm
Device height	68mm (DIN rail acc to EN60715)	68mm (DIN rail acc to EN60715)	68mm (DIN rail acc to EN60715)
Device width	36mm (2 x Module units 18mm)	36mm (2 x Module units 18mm)	36mm (2 x Module units 18mm)
Degree of protection	IP20	IP20	IP20
Upper and lower terminals	open mounted/lift terminals	open mounted/lift terminals	open mounted/lift terminals
Terminal capacity	1-25mm <sup>2</sup>	1-25mm <sup>2</sup>	1-25mm <sup>2</sup>
Terminal screw	M5 (Pozidrive PZ2)	M5 (Pozidrive PZ2)	M5 (Pozidrive PZ2)
Terminal torque	2-2,5Nm	2-2,5Nm	2-2,5Nm
Busbar thickness	0,8 - 2 mm	0,8 - 2 mm	0,8 - 2 mm
Operating temperature	-25°C ... +55°C	-25°C ... +55°C	-25°C ... +55°C
Storage and transport temperature	-40°C ... +70°C	-40°C ... +70°C	-40°C ... +70°C
Resistance to climatic conditions	IEC/EN 61008	IEC/EN 61008	IEC/EN 61008
Resistance to vibrations acc. to IEC 60068-2-7	5g (10,60 & 500Hz)	5g (10,60 & 500Hz)	5g (10,60 & 500Hz)
Contact position indicator	mechanical red/green	mechanical red/green	mechanical red/green
Supply possibility	Top or bottom	Top or bottom	Top or bottom
Mounting position	any	any	any

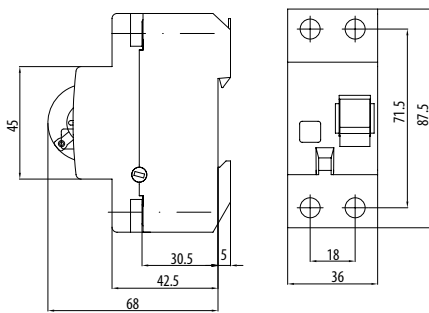

EFI-2 16-80 A

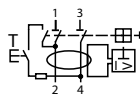

EFI-2 100 A

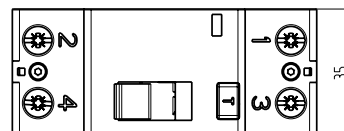
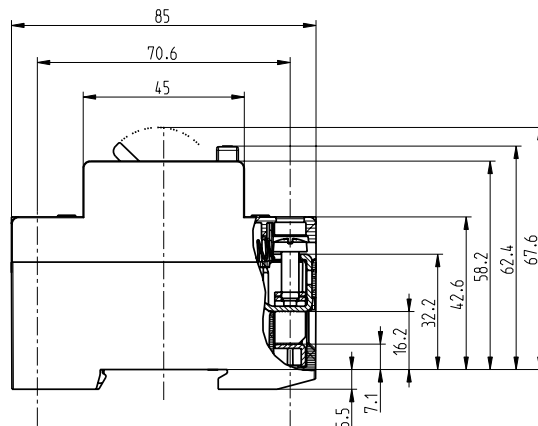

EFI-2 100 A

## Technical data

$I_n$	Powerlost EFI-2 G/KV & S type
	P / pole (W)
25A	1,29-1,43
40A	2,80 - 3,05
63A	4,28 - 5,34

Conductor cross-section [mm <sup>2</sup> ]	Number of single conductors, rigid, single-wire CU conductor				
	1	2	3	4	5
1,5	✓	✓	✓	✓	✗
2,5	✓	✓	✓	✗	✗
4	✓	✓	✓	✗	✗
6	✓	✓	✗	✗	✗
10	✓	✓	✗	✗	✗
16	✓	✗	✗	✗	✗
25	✓	✗	✗	✗	✗

Remark: When you use more than 2 cables you have to be careful how those cables are inserted, due to insure proper pressure on each cable

Conductor cross-section [mm <sup>2</sup> ]	Number of single conductors, flexible Cu conductors without cable ferrule					
	1	2	3	4	5	6
1,5	✓	✓	✓	✓	✓	✓
2,5	✓	✓	✓	✓	✓	✓
4	✓	✓	✓	✓	✓	✓
6	✓	✓	✓	✗	✗	✗
10	✓	✓	✗	✗	✗	✗
16	✓	✗	✗	✗	✗	✗
25	✓	✗	✗	✗	✗	✗

Combination of rigid single-wire and flexible multi-wire Cu conductors is not allowed

## Residual current circuit breaker EFI-4

Technical data			
Type	Instantaneous	G/KV type	S type
<b>Electrical</b>			
Rated voltage $U_n$	400/415V AC	400/415V AC	400/415V AC
Rated current $I_n$	16, 25, 40, 63, 80, 100A	25, 40, 63A	25, 40, 63A
Rated Insulation voltage $U_i$	440V	440V	440V
Rated frequency $f_n$	50/60Hz	50/60Hz	50/60Hz
Peak withstand current	-	3kA (8/20ms) surge current proof	5kA (8/20ms) surge current proof
Electrical isolation	> 4mm contact space	> 4mm contact space	> 4mm contact space
Rated residual operating current $I_{\Delta n}$	0,03; 0,1 & 0,3A	0,03; 0,1 & 0,3A	0,1 & 0,3A
Rated conditional short-circuit current $I_{cn}$	10kA	10kA	10kA
Rated making and breaking capacity $I_m$	800A	630A	630A
Maximum back-up fuse	100A gG	80A gG	80A gG
Isolation class	B	B	B
Standard	IEC/EN 61008	IEC/EN 61008, OVE E 8601	IEC/EN 61008
Mechanical endurance (op. c.)	> 4000	> 4000	> 4000
Electrical endurance (op. c.)	> 2000	> 2000	> 2000
<b>Mechanical</b>			
Frame size	45mm	45mm	45mm
Device height	68mm (DIN rail acc to EN60715)	68mm (DIN rail acc to EN60715)	68mm (DIN rail acc to EN60715)
Device width	72mm (4 x Module units 18mm)	72mm (4 x Module units 18mm)	72mm (4 x Module units 18mm)
Degree of protection	IP20	IP20	IP20
Upper and lower terminals	open mounted/lift terminals	open mounted/lift terminals	open mounted/lift terminals
Terminal capacity	1-25mm <sup>2</sup>	1-25mm <sup>2</sup>	1-25mm <sup>2</sup>
Terminal screw	M5 (Pozidrive PZ2)	M5 (Pozidrive PZ2)	M5 (Pozidrive PZ2)
Terminal torque	2-2,5Nm	2-2,5Nm	2-2,5Nm
Busbar thickness	0,8 - 2 mm	0,8 - 2 mm	0,8 - 2 mm
Operating temperature	-25°C ... +55°C	-25°C ... +55°C	-25°C ... +55°C
Storage and transport temperature	-40°C ... +70°C	-40°C ... +70°C	-40°C ... +70°C
Resistance to vibrations acc. to IEC 60068-2-7	5g (10,60 & 500Hz)	5g (10,60 & 500Hz)	5g (10,60 & 500Hz)
Resistance to climatic conditions	IEC/EN 61008	IEC/EN 61008	IEC/EN 61008
Contact position indicator	mechanical red/green	mechanical red/green	mechanical red/green
Supply possibility	Top or bottom	Top or bottom	Top or bottom
Mounting position	any	any	any



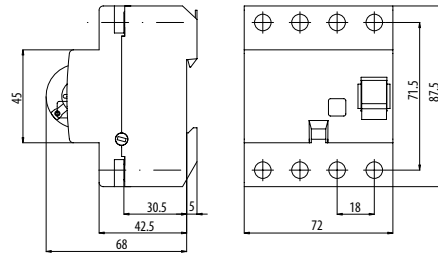
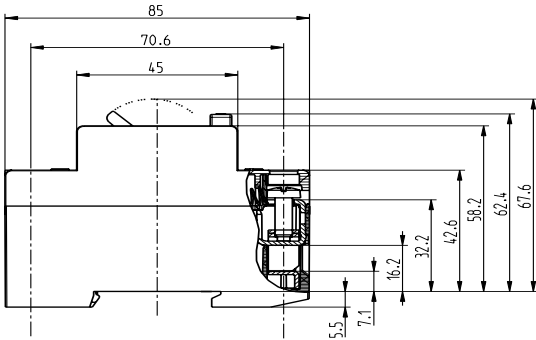

EFI-4 16-80 A

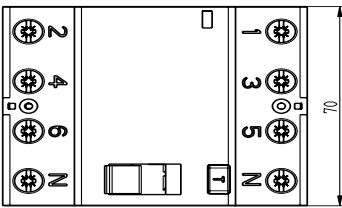

EFI-4 100 A

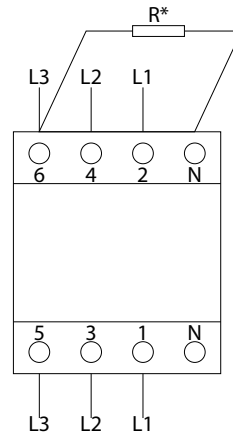
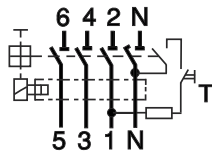

RCD EFI-4 Type in 3-phase system without neutral conductor:

- 30mA: R=4k7/1W (500V)
- 100mA: R=1k/1W (500V)
- 300mA: R=1k6/1W (500V)
- 500mA: R=1k6/1W (500)

\* Resistor (R) has to be connected between N and L3 as to ensure proper functionality of the test button.

$I_n$	Powerlost EFI-4 G/KV & S type
	P / pole (W)
25A	1,40-1,61
40A	2,73 - 4,11
63A	4,76 - 5,69

Conductor cross-section [mm <sup>2</sup> ]	Number of single conductors, rigid, single-wire CU conductor				
	1	2	3	4	5
1,5	✓	✓	✓	✓	✗
2,5	✓	✓	✓	✗	✗
4	✓	✓	✓	✗	✗
6	✓	✓	✗	✗	✗
10	✓	✓	✗	✗	✗
16	✓	✗	✗	✗	✗
25	✓	✗	✗	✗	✗

Remark: When you use more than 2 cables you have to be careful how those cables are inserted, due to insure proper pressure on each cable

Conductor cross-section [mm <sup>2</sup> ]	Number of single conductors, flexible Cu conductors without cable ferrule					
	1	2	3	4	5	6
1,5	✓	✓	✓	✓	✓	✓
2,5	✓	✓	✓	✓	✓	✓
4	✓	✓	✓	✓	✓	✓
6	✓	✓	✓	✗	✗	✗
10	✓	✓	✗	✗	✗	✗
16	✓	✗	✗	✗	✗	✗
25	✓	✗	✗	✗	✗	✗

Combination of rigid single-wire and flexible multi-wire Cu conductors is not allowed

Technical data

B and B+ type residual current circuit breaker EFI-4

Technical data		
Type	B & B+	
<b>Electrical</b>		
Design according to	IEC/EN 61008, IEC/EN 62423 B+ -> VDE 0664-400	
Current test marks as printed onto the device		
Rated voltage $U_n$	230/400 V AC	
Rated frequency $f_n$	50/60Hz	
Mode of operation	"A type functionality: voltage independent B and B+ type functionality: voltage dependent"	
Operation voltage electronic	50 – 253V AC	
Voltage range test circuit	196 – 253V AC	
Rated residual operating current $I_{\Delta n}$	Instantaneous	30, 100, 300 mA
	K - short time delayed	30, 100, 300 mA
	S - selective	100, 300 mA
Sensitivity	Alternating, pulsed and smooth direct currents	
Rated insulation voltage $U_i$	440 V	
Rated impulse withstand voltage $U_{imp}$	4 kV (1.2/50µs)	
Rated conditional short-circuit current $I_{cn}$	10 kA	
Rated making and breaking capacity $I_m$	800 A	
Peak withstand current	3 kA (8/20 µs) surge current proof	
Electrical isolation	> 4 mm contact space	
Maximum back-up fuse $I_n = 25-63A$	Short circuit and overload protection 100 A gG/gL	
Endurance (operating cycles)	electrical components	≥ 2000
	mechanical components	≥ 4000
<b>Mechanical</b>		
Frame size	45 mm	
Device height	68 mm (DIN rail acc to EN60715)	
Device width	72 mm (4xModule Units 18mm)	
Degree of protection	IP20	
Upper and lower terminals	open mounted/lift terminals	
Terminal protection finger and hand touch safe	IEC/EN 61008	
Terminal capacity	1 - 25 mm <sup>2</sup>	
Terminal screw	M5 (Pozidrive PZ2)	
Terminal torque	2 - 2.5 Nm	
Busbar thickness	0.8 - 2 mm	
Operating temperature	-25°C ... +55°C	
Storage- and transport temperature	-40°C ... +70°C	
Resistance to vibrations acc. to IEC 60068-2-7	5g (10,60 & 500Hz)	
Resistance to climatic conditions	IEC/EN 61008	
Contact position indicator	mechanical red / green	
Supply possibility	top or bottom	
Mounting position	any	

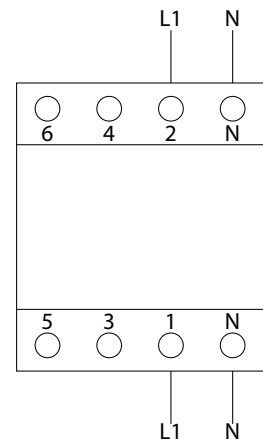

RCD ETI Type B & B+ in 1-phase system  $U_n=230V$

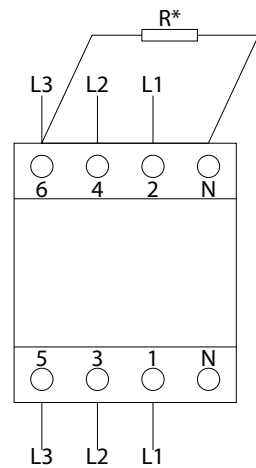

RCD ETI Type B & B+ in 3-phase system without neutral conductor -  $U_n=400V$   
 30mA: R=2k7/1W (500V)  
 100mA: R=7k5/1W (500V)  
 300mA: R=2k7/1W (500V)

\* Resistor (R) has to be connected between N and L3 as to ensure proper functionality of the test button.

Conductor cross-section [mm <sup>2</sup> ]	Number of single conductors, rigid, single-wire CU conductor				
	1	2	3	4	5
1,5	✓	✓	✓	✓	✗
2,5	✓	✓	✓	✗	✗
4	✓	✓	✓	✗	✗
6	✓	✓	✗	✗	✗
10	✓	✓	✗	✗	✗
16	✓	✗	✗	✗	✗
25	✓	✗	✗	✗	✗

Remark: When you use more than 2 cables you have to be careful how those cables are inserted, due to insure proper pressure on each cable

Conductor cross-section [mm <sup>2</sup> ]	Number of single conductors, flexible Cu conductors without cable ferrule					
	1	2	3	4	5	6
1,5	✓	✓	✓	✓	✓	✓
2,5	✓	✓	✓	✓	✓	✓
4	✓	✓	✓	✓	✓	✓
6	✓	✓	✓	✗	✗	✗
10	✓	✓	✗	✗	✗	✗
16	✓	✗	✗	✗	✗	✗
25	✓	✗	✗	✗	✗	✗

Combination of rigid single-wire and flexible multi-wire Cu conductors is not allowed

K-Short time delay, S-Selective

Instantaneous

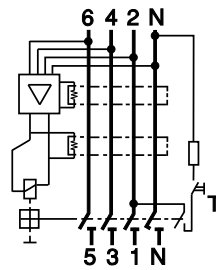
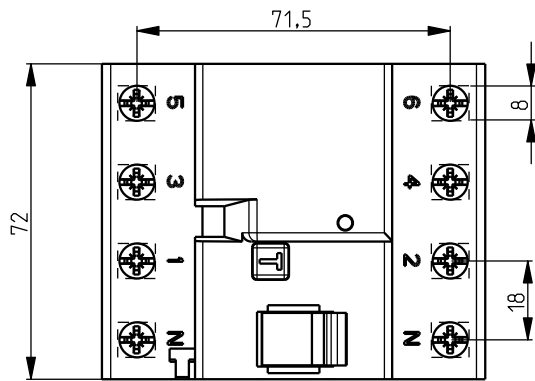
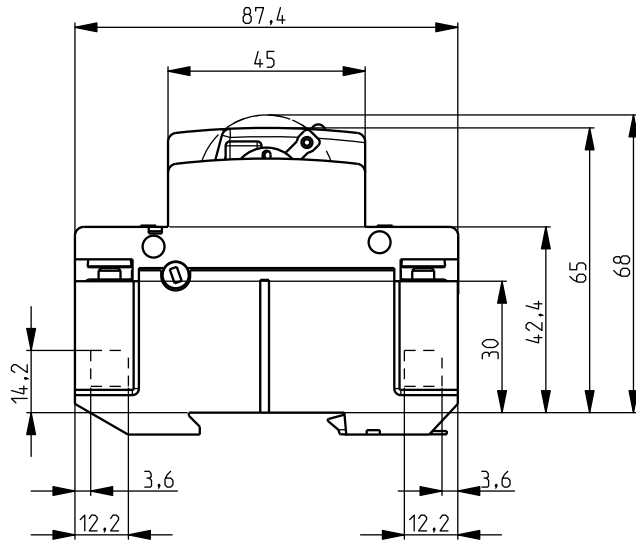
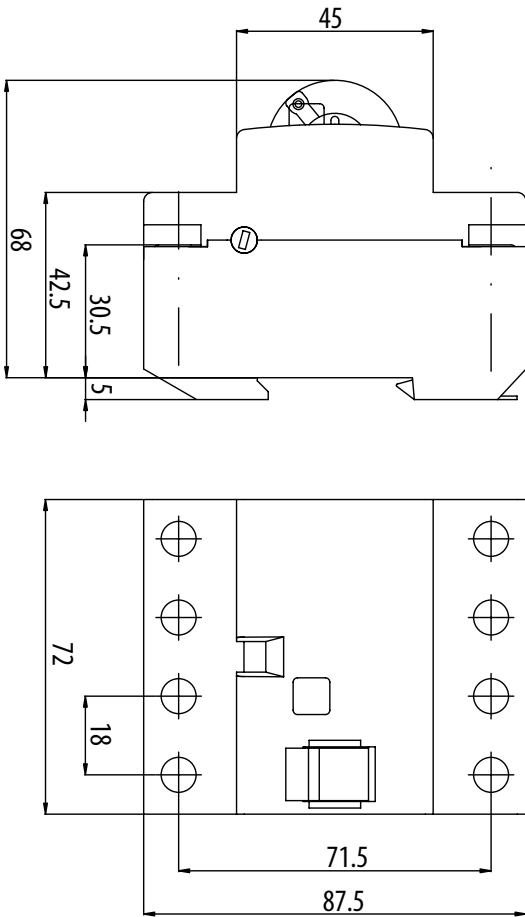

Technical data

EFI B type

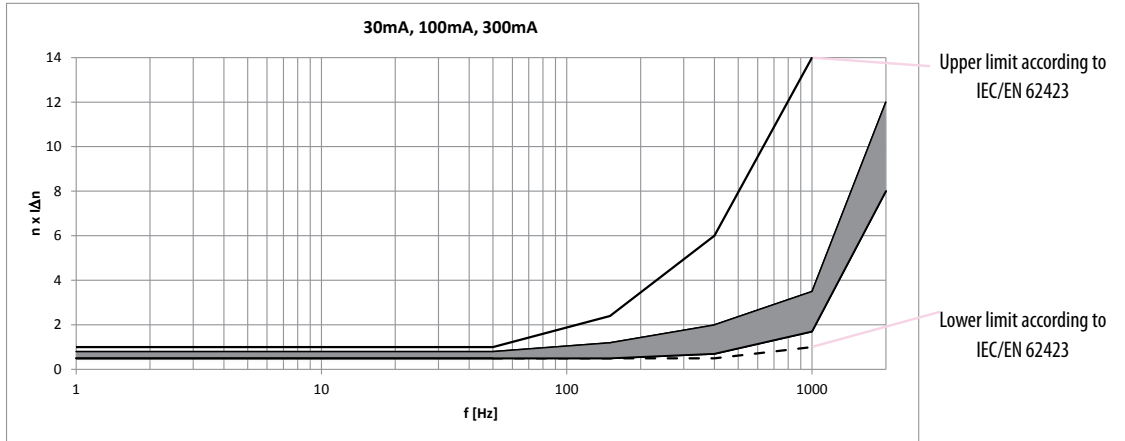

EFI B+ type

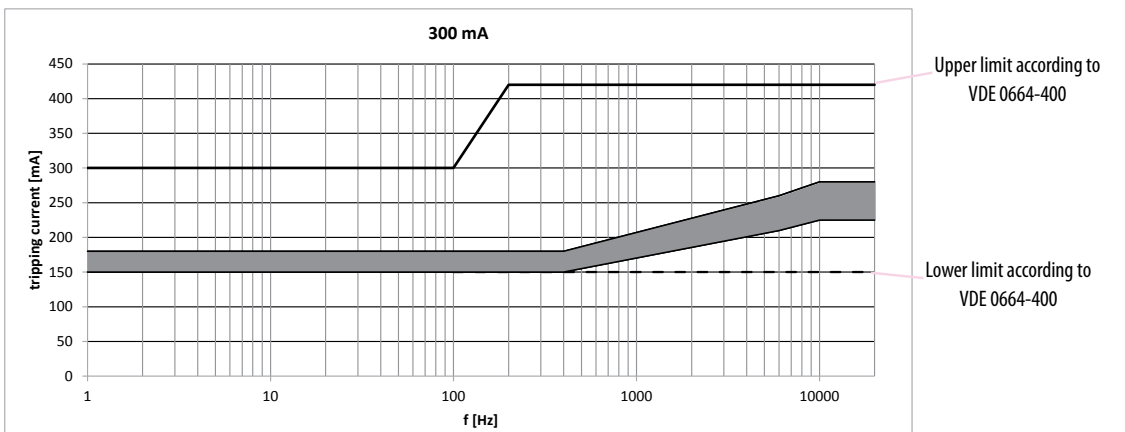
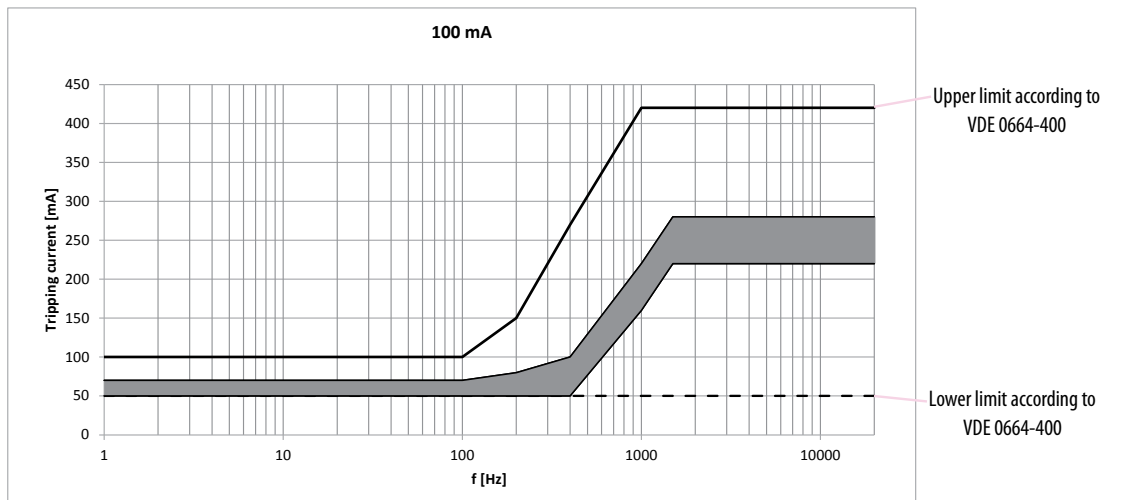
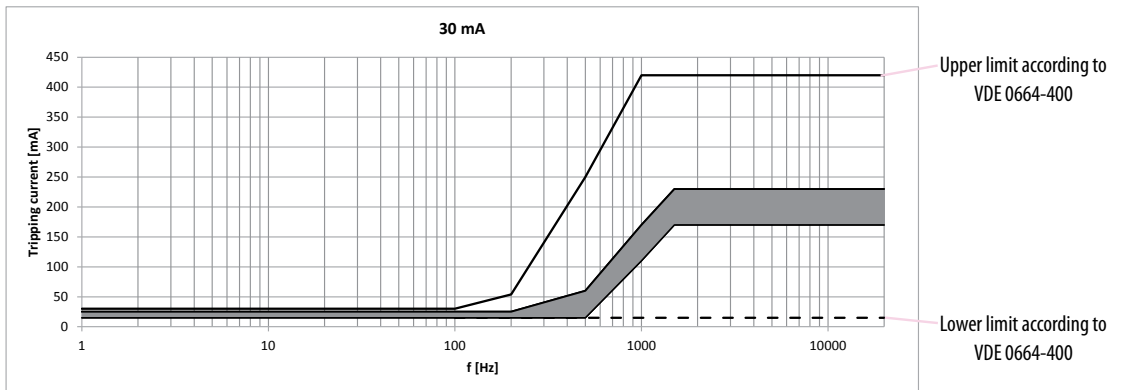

## Auxiliary switch PS EFI

### Technical data

Rated current $I_n$	6 A (230 V AC), AC 12, 1 A (110 V DC), DC 12
Conditional short-circuit current	1 kA with fuse-link 20 A
Mounting position	any
Standards	EN 62019

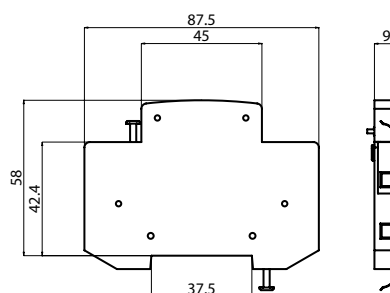

## Shunt trip release DA EFI

### Technical data

Rated voltage	230V AC
Rated frequency	50/60Hz
Max inrush current	0,8A
Build-in width	9mm
Mounting position	any

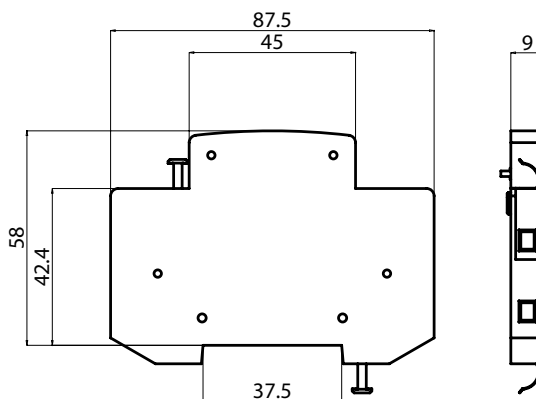
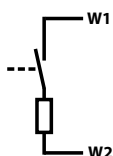

## Residual current circuit breaker with integral overcurrent protection KZS -1M

### Technical data

Type	KZS 1M	KZS 1M FN
Rated voltage $U_n$	230 V AC	
Rated current $I_n$	6-25 A	6-45 A
Minimal supply voltage $U_{min}$	90 V	
Rated frequency $f_n$	50 Hz	
Rated short-circuit capacity	6.000 A	10.000 A
Back-up fuse	100 A gG	
Tripping characteristic	B, C	
Rated residual current $I_{\Delta n}$	10, 30, 100 mA	30, 100 mA
Type of residual release	A, AC	
Rated residual making and breaking capacity $I_{\Delta m}$	1500A	4500A
Terminals	1-10 mm <sup>2</sup> , max. 1,5Nm	1-25 mm <sup>2</sup> / 1-16 mm <sup>2</sup>
Terminal screw	M4 (Pozidrive PZ2)	M5 (Pozidrive PZ2)
Width	18 mm	
Mounting position	any	
Standard	IEC 61009	IEC 61009-1 / 61009-2
Length of neutral conductor	-	600 mm
Operating temperature	-25°C ... +40°C	

Technical data

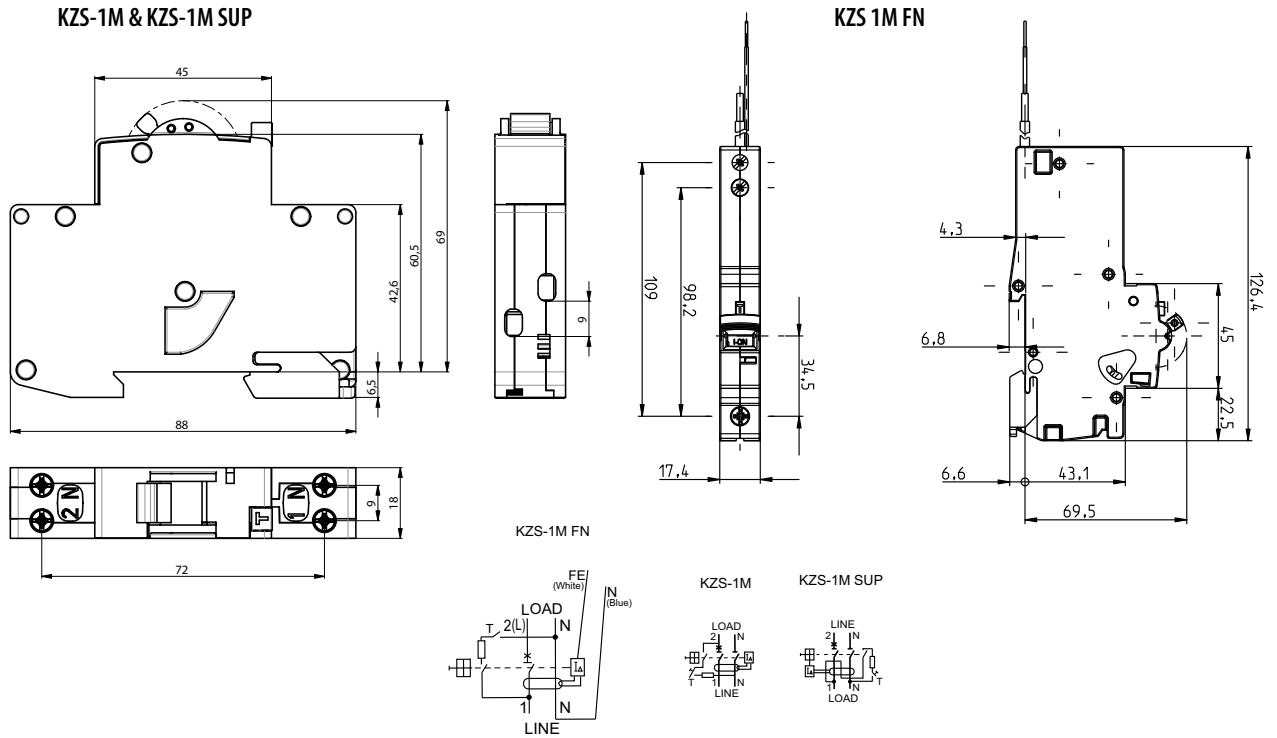

Residual current circuit breaker with integral overcurrent protection KZS-2M

Technical data		
Type	INST	G/KV
Rated voltage $U_n$	230 V AC	
Rated current $I_n$	6-40 A	4-40A
Rated frequency $f_n$	50/60 Hz	
Rated short-circuit capacity	10.000 A	
Back-up fuse	100 A gG	
Tripping characteristic	B, C	
Type	A, AC	
Rated residual current $I_{\Delta n}$	10, 30, 100, 300, 500 mA	30 mA
Peak withstand current	250 A	3 kA
Rated residual making and breaking capacity $I_{\Delta m}$	10.000A	
Terminals	1-25 mm <sup>2</sup> , max. 3Nm	
Terminal screw	M5 (PoziDrive PZ2)	
Width	36 mm	
Mounting position	any	
Resistance to vibrations acc. to IEC 60068-2-7	5g (10,60 & 500Hz)	
Standard	IEC 61009, EN 61009	

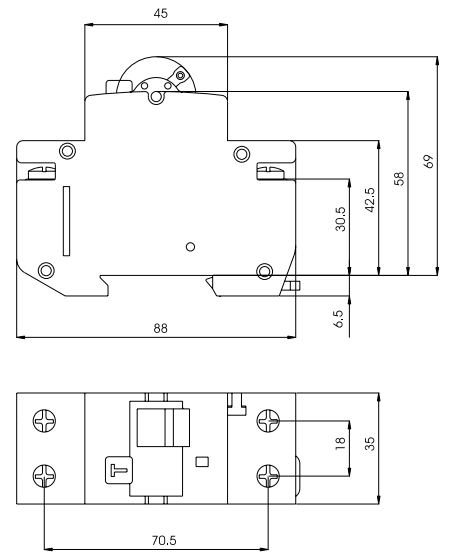

Conductor cross-section [mm <sup>2</sup> ]	Number of single conductors, rigid, single-wire CU conductor				
	1	2	3	4	5
1,5	✓	✓	✓	✓	✗
2,5	✓	✓	✓	✗	✗
4	✓	✓	✓	✗	✗
6	✓	✓	✗	✗	✗
10	✓	✓	✗	✗	✗
16	✓	✗	✗	✗	✗
25	✓	✗	✗	✗	✗

Conductor cross-section [mm <sup>2</sup> ]	Number of single conductors, flexible Cu conductors without cable ferrule					
	1	2	3	4	5	6
1,5	✓	✓	✓	✓	✓	✓
2,5	✓	✓	✓	✓	✓	✓
4	✓	✓	✓	✓	✓	✓
6	✓	✓	✓	✗	✗	✗
10	✓	✗	✗	✗	✗	✗
16	✓	✗	✗	✗	✗	✗
25	✓	✗	✗	✗	✗	✗

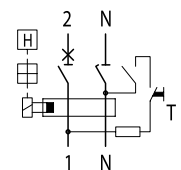

Remark: When you use more than 2 cables you have to be careful how those cables are inserted, due to insure proper pressure on each cable

Combination of rigid single-wire and flexible multi-wire Cu conductors is not allowed

Residual current circuit breaker with integral overcurrent protection KZS-R

Technical data	
Rated Voltage $U_n$	230V
Rated Current $I_n$	6-32A
Rated frequency	50/60Hz
Rated insulation Voltage $U_i$	240V
Rated short-circuit capacity	10kA
Max back-up fuse	gG 100A
Tripping characteristic	B & C
Type	A
Rated residual current $I_{\Delta n}$	10, 30mA
Rated residual making and breaking capacity $I_{\Delta m}$	10.000 A
Peak withstand current	250A (8/20ms) surge current proof
Rated impulse withstand voltage $U_{imp}$	4kV (1.2/50ms)
Electrical isolation	> 4mm contact space
Insulating class	VDE 0110
Mechanical endurance (cycles)	> 10.000
Electrical endurance (cycles)	> 3.000
Standards	IEC/EN 61009
Frame size	45mm
Device height	70 mm (DIN rail acc to EN60715)
Device width	36 mm (2 Module units)
Degree of protection	IP 20
Upper and lower terminals	open mounted/lift terminals
Terminal capacity	1-25mm <sup>2</sup>
Terminal screw	M5 (Pozidrive PZ2)
Terminal torque	max 2Nm
Busbar thickness	0.8 - 2mm
Operating temperature	- 25°C ... + 40°C
Storage and transport temperature	- 40°C ... + 70°C
Resistance to climatic conditions	IEC/EN 61009
Contact position indicator	mechanical red/green
Supply possibility	top or bottom

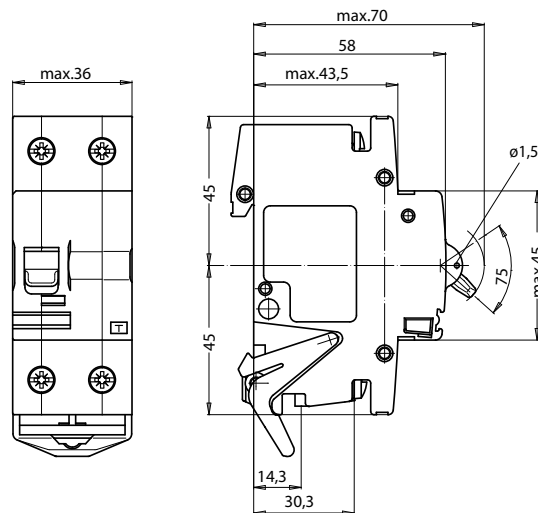

Technical data

Auxiliary signal switch PS/SS KZS-R

Technical data	
Rated voltage	230V AC/DC, 110V DC
Rated current	6A (230V AC); 1A (110V DC); 0,5A (220V DC)
Rated frequency	50/60Hz, DC
Index of protection	IP 20 (IP 40)
Terminals	max. 1.5mm <sup>2</sup> , max 0.8Nm
Ambient temperature	max. 35°C
Storage temperature	max. -40°C to +70°C
Contacts	1x NC, 1x NC/NO
Mounting position	any
Standards	EN 62019

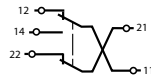
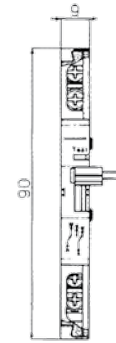

NO - Normally open contact --> during the activation it makes a contact  
 NC - Normally closed contact --> during the activation it brakes the contact  
 1 - contact  
 0 - without a contact

AUX switch connections	status of the breaker	
	ON	OFF
11-14 NO	1	0
11-12 NC	0	1
21-22 NC	0	1

Signal switch connections	status of the breaker		
	ON	manual trip	overcurrent trip
11-14 NO	1	1	0
11-12 NC	0	0	1
21-22 NC	0	0	1

Residual current circuit breaker with integral overcurrent protection KZS-2M 2p

Technical data	
Rated voltage $U_n$	230 V AC
Rated current $I_n$	6-25 A
Rated frequency $f_n$	50 Hz
Rated short-circuit capacity	10.000 A
Back-up fuse	100 A gG
Tripping characteristic	B, C
Type	A
Rated residual current $I_{\Delta n}$	30, 100 mA
Rated residual making and breaking capacity $I_{\Delta m}$	1500A
Terminals	1-25 mm <sup>2</sup> , max. 3Nm
Terminal screw	M5 (PoziDrive PZ2)
Width	36 mm
Mounting position	any
Resistance to vibrations acc. to IEC 60068-2-7	5g (10,60 & 500Hz)
Standard	IEC 61009, EN 61009

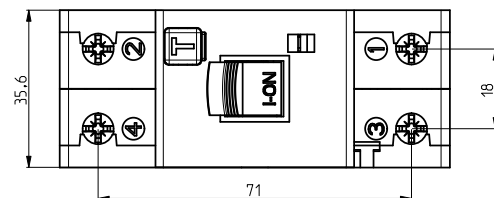
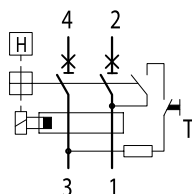
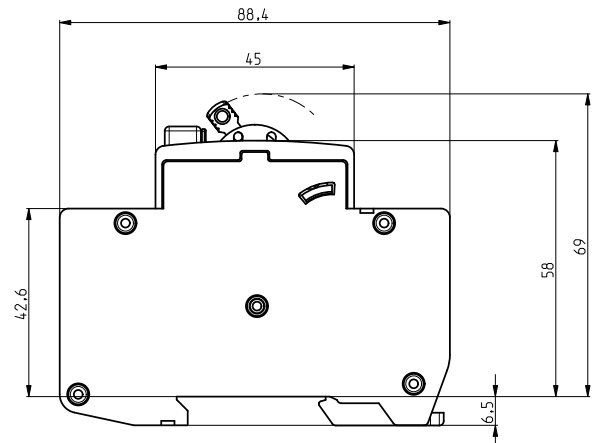



Residual current circuit breaker with integral overcurrent protection with LED status signalisation KZS 2M2p EDI

**Technical data**

Rated voltage $U_n$	~230 V AC
Rated current $I_n$	6-25 A
Rated frequency $f_n$	50 Hz
Minimal supply voltage $U_{min}$	90 V
Min. LED operating voltage $U_{min}$	150 V
Rated short-circuit capacity	10.000 A
Back-up fuse	100 A gG
Tripping characteristic	B, C
Energy limiting class	3
Type of residual release	A
Rated residual current $I_{\Delta n}$	30 mA
Rated residual making and breaking capacity $I_{\Delta m}$	1500A
Index of protection	IP20
Overvoltage category	III
Ambient temperature	-25 °C ... +40 °C
Storage temperature	-40 °C ... +70 °C
Mounting position	any
Terminals	1-25 mm <sup>2</sup> , max. 3 Nm
Terminal screw	M5 (Pozidrive PZ2)
Width	36 mm
Resistance to vibrations acc. to IEC 60068-2-7	5g (10,60 & 500Hz)
Standard	IEC 61009-2, IEC 61009-1

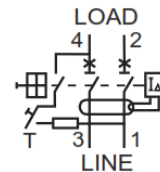
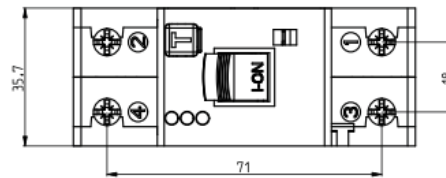
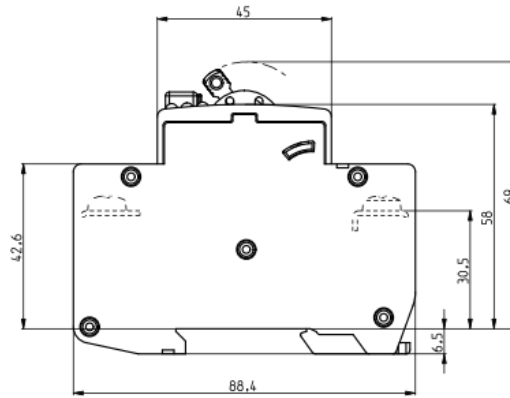

Residual current circuit breaker with integral overcurrent protection KZS-4M 3p

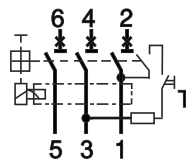
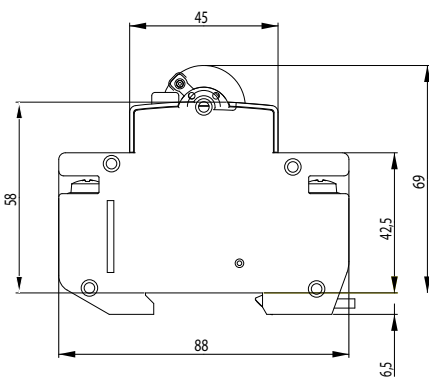

**Technical data**

Rated voltage $U_n$	~400 V AC
Rated current $I_n$	6-32 A
Rated frequency $f_n$	50/60 Hz
Rated short-circuit capacity	10.000 A
Back-up fuse	100 A gG
Tripping characteristic	B, C
Type	AC, A
Rated residual current $I_{\Delta n}$	30, 100, 300, 500 mA
Rated residual making and breaking capacity $I_{\Delta m}$	4500A
Terminals	1-25 mm <sup>2</sup> , max. 3 Nm
Terminal screw	M5 (Pozidrive PZ2)
Width	72 mm
Mounting position	any
Standard	EN 61009-1

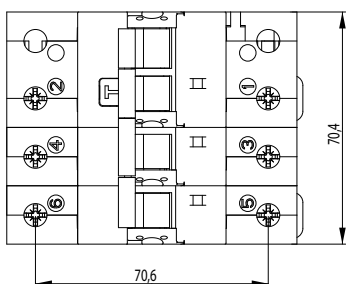

Conductor cross-section [mm <sup>2</sup> ]	Number of single conductors, rigid, single-wire CU conductor				
	1	2	3	4	5
1,5	✓	✓	✓	✓	✗
2,5	✓	✓	✓	✗	✗
4	✓	✓	✓	✗	✗
6	✓	✓	✗	✗	✗
10	✓	✓	✗	✗	✗
16	✓	✗	✗	✗	✗
25	✓	✗	✗	✗	✗

Remark: When you use more than 2 cables you have to be careful how those cables are inserted, due to insure proper pressure on each cable

Conductor cross-section [mm <sup>2</sup> ]	Number of single conductors, flexible Cu conductors without cable ferrule					
	1	2	3	4	5	6
1,5	✓	✓	✓	✓	✓	✓
2,5	✓	✓	✓	✓	✓	✓
4	✓	✓	✓	✓	✓	✓
6	✓	✓	✓	✗	✗	✗
10	✓	✓	✗	✗	✗	✗
16	✓	✗	✗	✗	✗	✗
25	✓	✗	✗	✗	✗	✗

Combination of rigid single-wire and flexible multi-wire Cu conductors is not allowed

Technical data

Residual current circuit breaker with integral overcurrent protection KZS-4M 3p+N

Technical data	
Rated voltage $U_n$	~400 V AC
Rated current $I_n$	6-32 A
Rated frequency $f_n$	50/60 Hz
Rated short-circuit capacity	6.000 A
Back-up fuse	100 A gG
Tripping characteristic	B, C
Type	AC, A
Rated residual current $I_{dn}$	30, 100, 300, 500 mA
Rated residual making and breaking capacity $I_{dm}$	4500A
Terminals	1-25 mm <sup>2</sup> , max. 3 Nm
Terminal screw	M5 (Pozidrive PZ2)
Width	70 mm
Mounting position	any
Standard	EN 61009-1

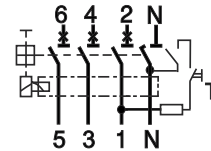
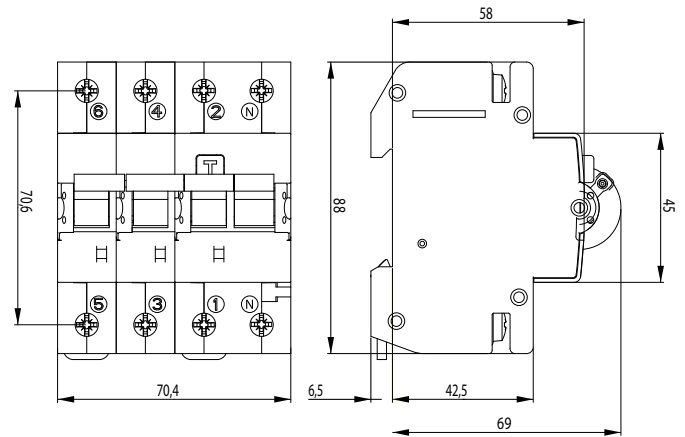

Residual current circuit breaker with integral overcurrent protection KZS-4M 2p B-type

Technical data	
<b>Electrical</b>	
Rated voltage $U_n$	230 V AC
Rated current $I_n$	6, 10, 13, 16, 20, 25, 32, 40 A
Rated Insulation voltage $U_i$	440 V
Peak withstand current	3kA (8/20ms) surge current proof
Electrical isolation	> 4mm contact space
Rated residual operating current $I_{dn}$	30, 100, 300mA
Rated short-circuit capacity	10kA
Maximum back-up fuse	100A gG
Isolation class	B
Standard	IEC/EN 61009-1, IEC/EN 62423
Mechanical endurance	20.000
Electrical endurance	10.000
<b>Mechanical</b>	
Frame size	45mm
Device height	69 mm
Device width	70 mm
Degree of protection	IP20
Upper and lower terminals	open mounted/lift terminals
Terminal capacity	1-25 mm <sup>2</sup>
Terminal screw	M5 (Pozidrive PZ2)
Terminal torque	max 3,0 Nm
Operating temperature	-25°C ... +60°C
Storage and transport temperature	-40°C ... +70°C
Resistance to climatic conditions	IEC/EN 61009
Contact position indicator	mechanical red/green
Supply possibility	Top or bottom

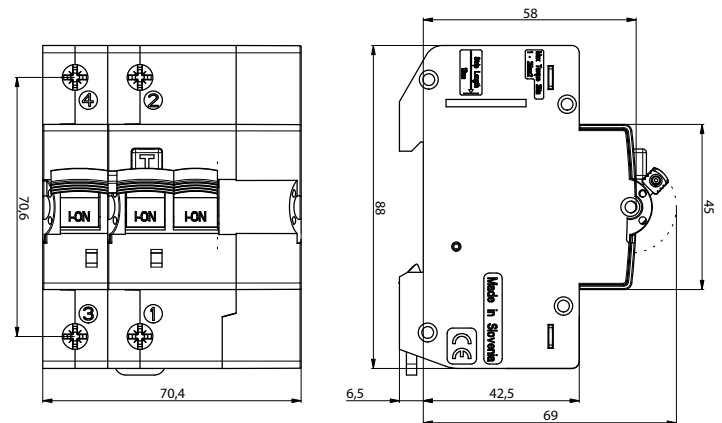

## Add-on block for residual current protection DIFO

Technical data	
Rated voltage $U_n$	230/400 V AC
Rated current $I_n$	$\leq 32$ A $\geq 40$ A
Rated frequency $f_n$	50 / 60 Hz
Rated residual current $I_{\Delta n}$	30, 100, 300 mA
Type of residual current tripping	AC, A
Terminals	1 – 25 mm <sup>2</sup> , max. 3 Nm
Terminal screw	M5 (Pozidrive PZ2)
Mounting position	any
Standards	IEC 61009, EN 61009

### DIFO2

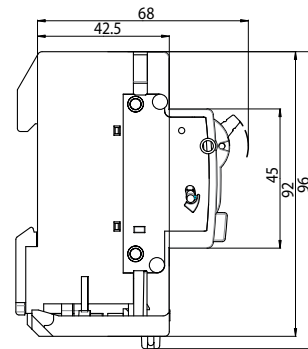
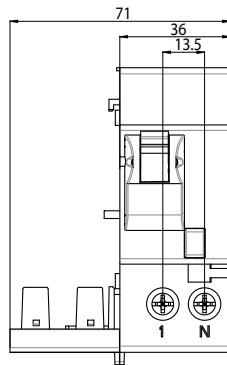
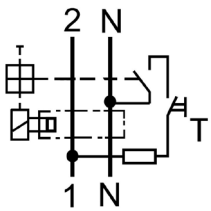

### DIFO4

